

**100-68**

Teileliste und Näheinrichtungen  
Parts List and Sewing Equipment

Alle Rechte vorbehalten.

Eigentum der Dürkopp Adler AG und urheberrechtlich geschützt. Jede Wiederverwendung dieser Inhalte, auch in Form von Auszügen, ist ohne vorheriges schriftliches Einverständnis der Dürkopp Adler AG verboten.

All rights reserved.

Property of Dürkopp Adler AG and protected by copyright. Any reuse of these contents, including extracts, is prohibited without the prior written approval of Dürkopp Adler AG.

Copyright © Dürkopp Adler AG 2017

Befestigung  
mounting  
012212.00

Fadenwächter  
thread monitor  
3402126.00

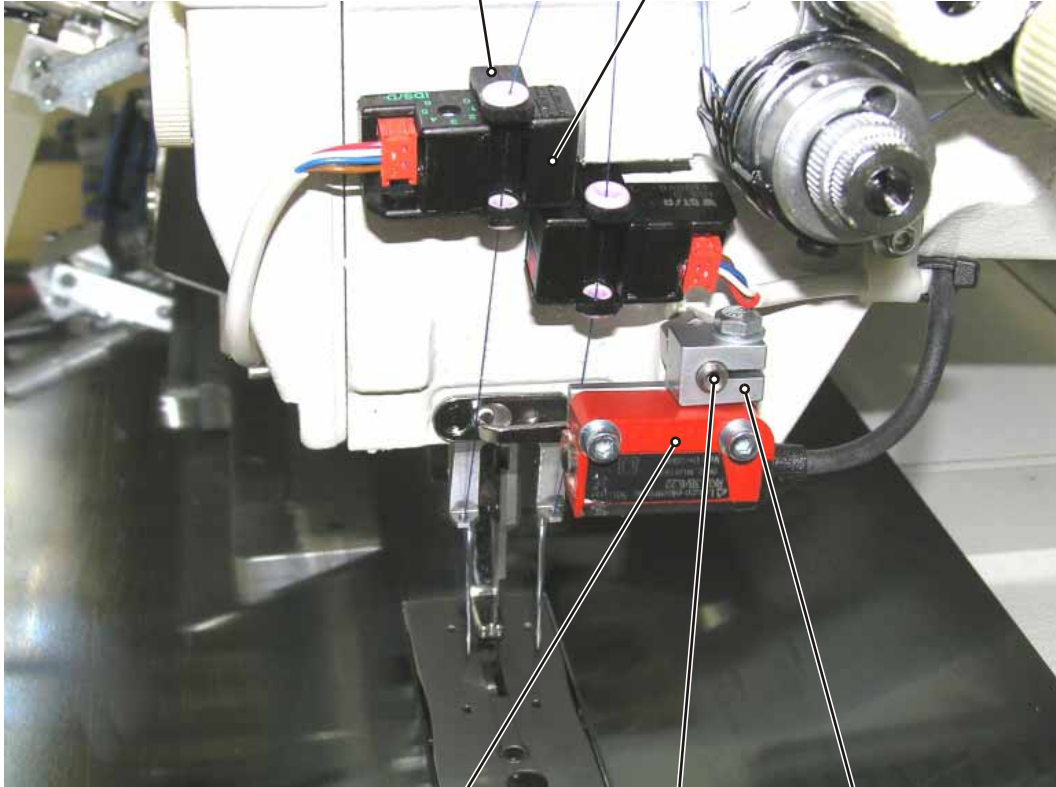

Reflexlichtschranke  
photocell  
2100743.10

Stehbolzen  
stay bolt  
012282.00

Halter  
holder  
012227.00

Achtung: Gültig ab 01.06.2007  
ATTENTION: Valid from 01.06.2007

Führung  
guide  
008404.01

Zylinder mit Feder  
cylinder with spring  
1000516.00

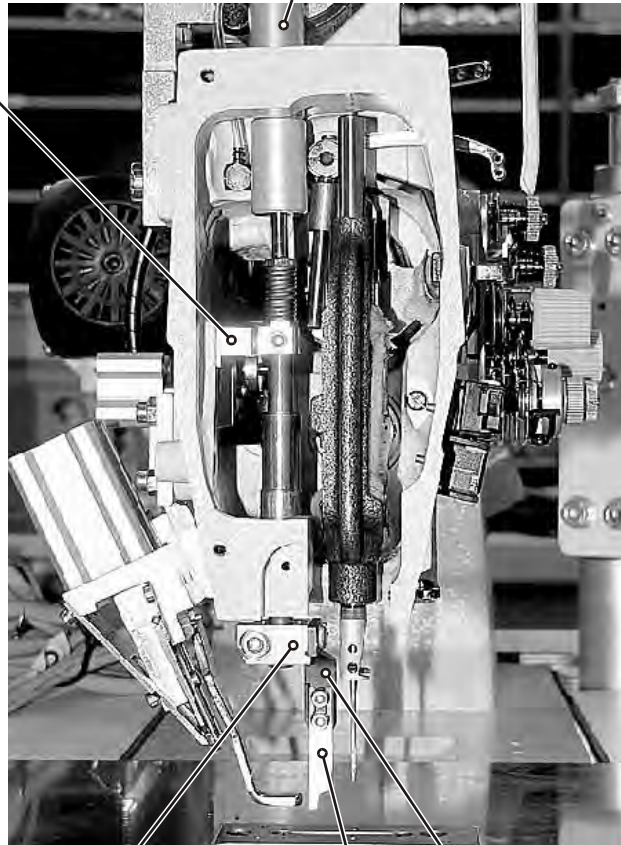

Messerhalter  
knife holder  
008416.00

Mittelmesser  
knife  
008688.00

Messerhalter  
knife holder  
012134.00

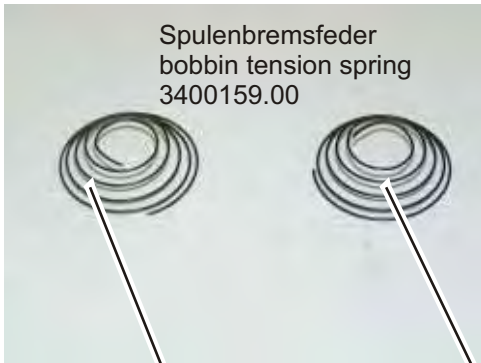

Spulenkapsel  
bobbin case  
008940.00

Spule  
bobbin  
008935.00

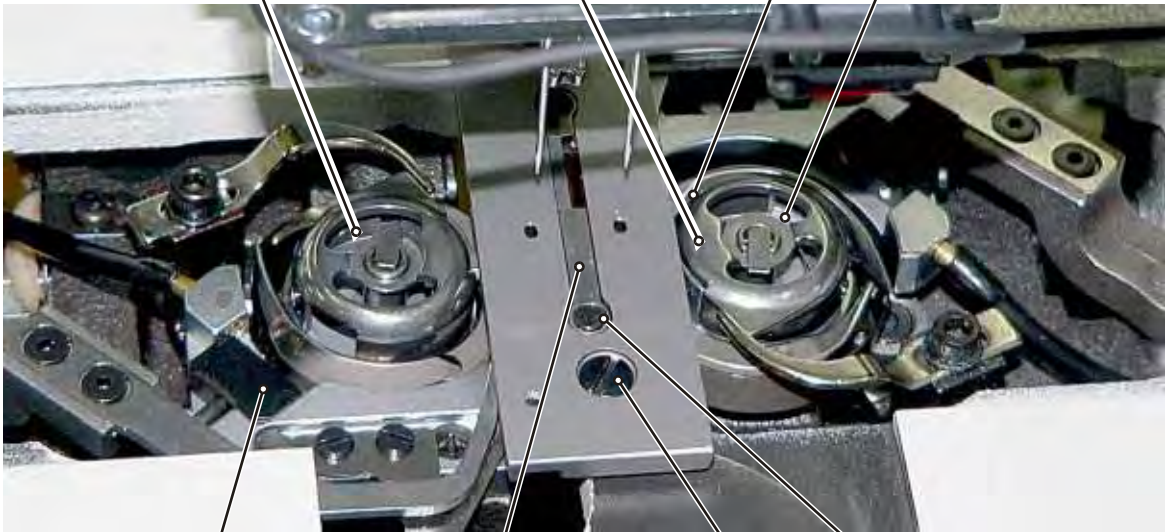

Tastkopf  
bobbin thread sensor  
2100754.30

Messer  
knife  
3400107.00

Schraube  
screw  
3400106.00

Schraube  
screw  
3400105.00

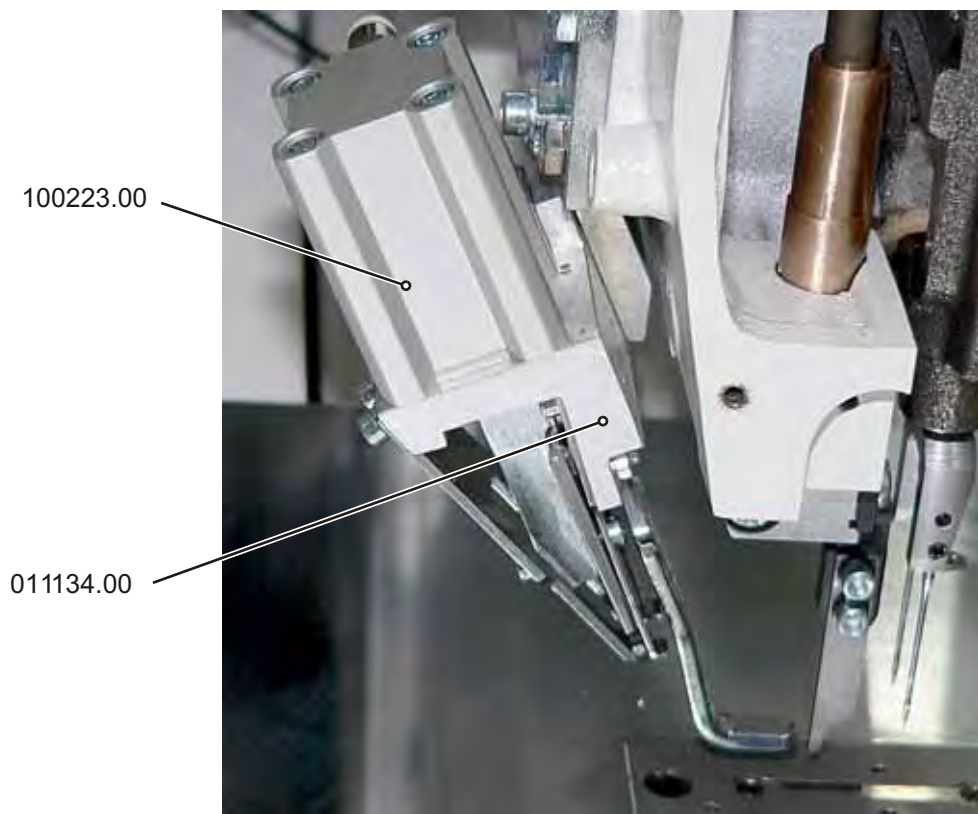

**Fadenfänger - thread catcher**

	<b>Halter</b>	<b>Messer knife</b>	<b>Bewegl. Messer movable knife</b>	<b>Federblech flat spring</b>	<b>Messerschutz knife guard</b>
					
NA4,8	012315.00	012312.00	012313.00	012314.00	012311.00
NA8	011135.01	3400608.15	3400608.16	3400608.17	3400610.10
NA10	011135.00	3400610.07	3400610.08	3400610.09	3400610.10
NA12	011135.00	3400610.07	3400610.08	3400610.09	3400610.10
NA14	011135.00	3400614.07	3400614.08	3400614.09	3400614.10
NA16	011135.00	3400614.07	3400614.08	3400614.09	3400614.10
NA18	011135.00	3400620.07	3400620.08	3400620.09	3400620.10
NA20	011135.00	3400620.07	3400620.08	3400620.09	3400620.10
NA22					
NA24	011135.00	3400624.07	3400624.08	3400624.09	3400624.10
NA26	011135.00	3400624.07	3400624.08	3400624.09	3400624.10
NA30	011135.00	3400624.07	3400624.08	3400624.09	3400624.10

Zahnriemen  
toothed belt  
011889.00

Schiene  
guide rail  
1500546.00

Wagen  
carriage  
1500547.00

Wagen  
carriage  
1500551.00

Schiene  
guide rail  
1500550.00

Messerkloben  
knife holder  
011778.00



Schrittmotor  
stepping motor  
012191.00

Zylinder  
cylinder  
1000507.00

Reedschalter + Befestigung + Gleitlager  
reed switch + mounting + bush bearing  
012186.00 + 1000508.10 + 012106.00

Abluftdrossel  
throttle valve  
006927.00

**Eckmesser Standard**  
**Eckmesser R    Eckmesser L**



NA8	3402229.00	3402230.00
NA10	3402219.00	3402220.00
NA12	3402221.00	3402222.00
NA14	3402223.00	3402224.00
NA16	3402223.00	3402224.00
NA18	3402223.00	3402224.00
NA20	3402223.00	3402224.00
NA22		
NA24	3402225.00	3402226.00
NA26	3402225.00	3402226.00
NA30	3402227.00	3402228.00

Vorstecher - Stift  
punch  
011779.00

Wagen  
carriage  
1500551.00



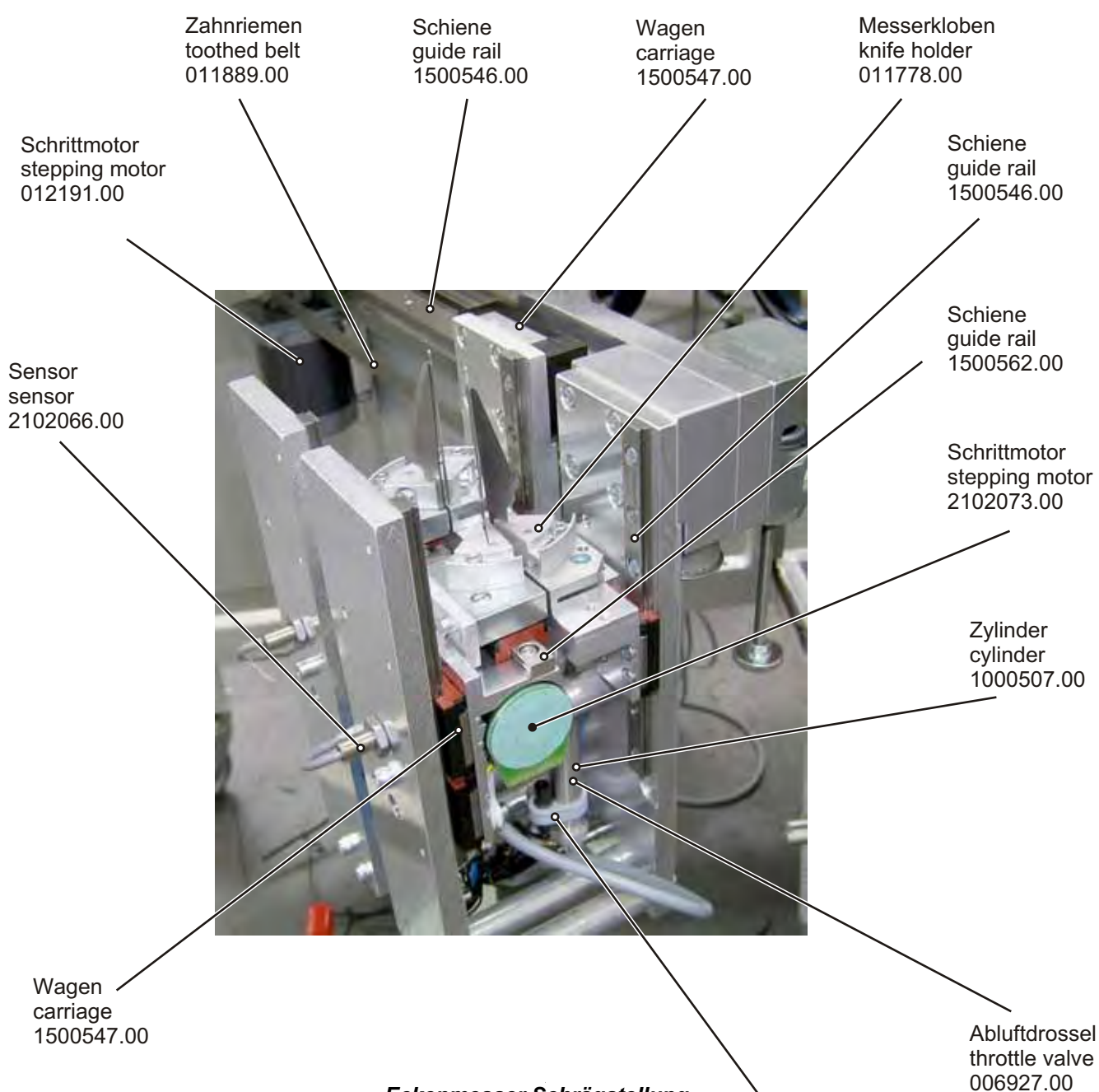

**Eckenmesser Schrägstellung**  
**Eckenmesser R Eckenmesser L**



NA8	3402207.00	3402208.00
NA10	3402207.00	3402208.00
NA12	3402209.00	3402210.00
NA14	3402211.00	3402212.00
NA16	3402213.00	3402214.00
NA18	3402213.00	3402214.00
NA20	3402215.00	3402216.00
NA22		
NA24	3402217.00	3402218.00
NA26	3402217.00	3402218.00
NA30	3402217.00	3402218.00

Reedschalter + Befestigung + Gleitlager  
 reed switch + mounting + bush bearing  
 012186.00 + 1000508.10 + 012106.00



Platine  
circuit board  
2102074.00



Platine  
circuit board  
2102075.00

Einspeisung  
start plate  
1100500.01

Endplatte  
finish plate  
1100500.02

Platine  
circuit board  
2102077.00

1100500.99

1100500.11

1100500.07

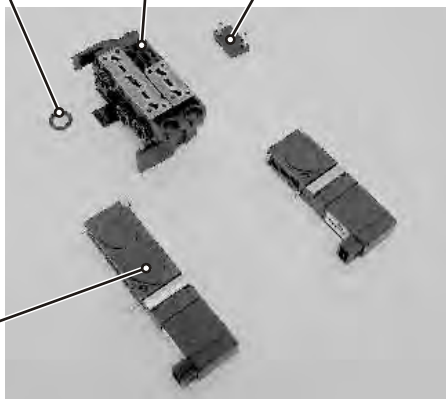

1100500.05

Rückschlagventil  
return valve  
1400337.00

Abluftdrossel  
throttle valve  
006927.00

Wegbegrenzung kompl.  
Limiters complete  
3402242.00

Lagerplatte rechts  
guide plate right  
011859.00



Lagerplatte links  
guide plate left  
011860.00

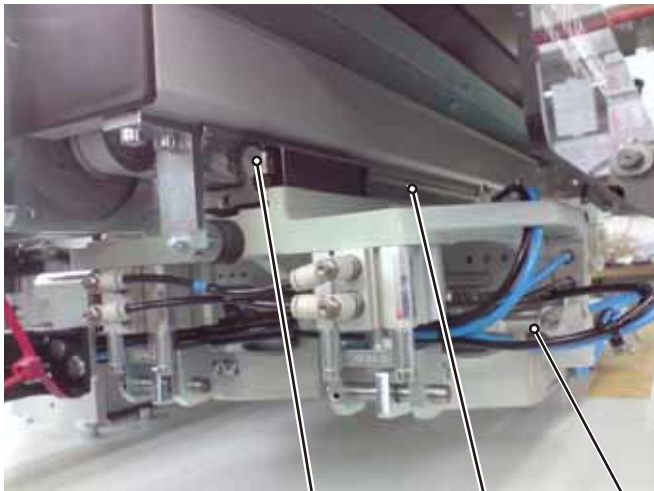

Wagen  
carriage  
1500543.00

Schiene  
guide rail  
1500542.00

Zylinder  
cylinder  
1000515.00

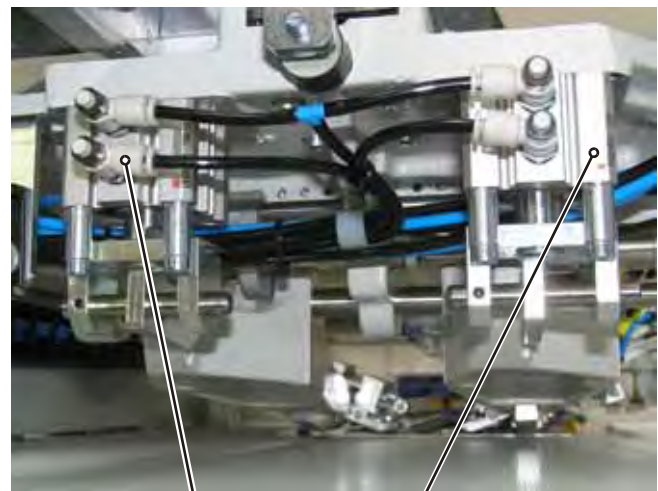

Zuluftdrossel  
throttle valve  
007418.00

Zylinder  
cylinder  
1000506.00

Pattenanschlag  
flap guide  
001284.00

Zylinder  
cylinder  
1000001.00

Abluftdrossel  
throttle valve  
006927.00

Zylinder  
cylinder  
1000220.00

Hebel  
lever  
008653.00

Anschlagklemme  
guide clamp  
001283.00

Pattenklammer links  
flap clamp links  
009061.00

Stelling  
set collar  
1600463.00

Abweisblech  
deflektor plate  
007571.00

Pattenklammer rechts  
flap clamp right  
009060.00

Anschlag  
guide  
001701.00

Gummibelag  
rubber coat  
009059.00

Klammergummi  
clamp rubber  
007487.00

Reflexfolie  
reflecting foil  
2500780.20

Distanzunterlage für dickes Material  
additional distance for thick material  
011634.00

Pattenanschlag  
flap guide  
001284.01

Anschlag  
guide  
008824.00+008825.00

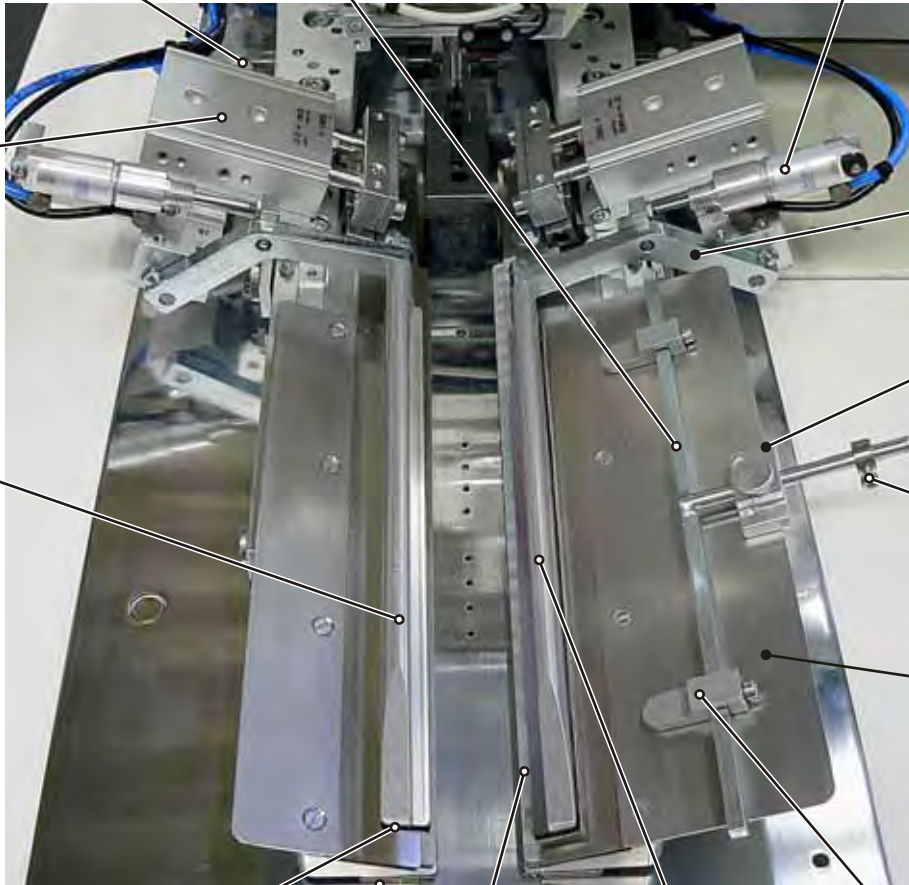

Platine für Ausroller  
electronic circuit for roller  
Elektronikplatine  
electronic circuit  
2102071.00



Elektronikplatine  
electronic circuit  
2102070.00  
IO - Platine für  
CAN - Schnittstelle  
IO - electronic circuit  
CAN - interface

Elektronikplatine  
electronic circuit  
2102071.00  
Fadenwächter  
thread monitor

Sicherung 4AT  
fuse 4AT

Elektronikplatine  
electronic circuit  
2102072.00  
Platine für Laser  
electronic circuit  
for laserpointer

ACHTUNG-nur Y10 Grundstellung geöffnet  
 ATTENTION- only Y10 normally open  
 Ventil 3/2 Wege NO  
 valve 3/2 NO  
 1100500.12



Einspeisung  
 start plate  
 1100500.01

Endplatte  
 finish plate  
 1100500.02

1100500.99

1100500.11

1100500.07

Ventil 3/2 Wege NC  
 valve 3/2 NC  
 1100500.03

Elektronik Platine  
 electronic circuit  
 2102058.00

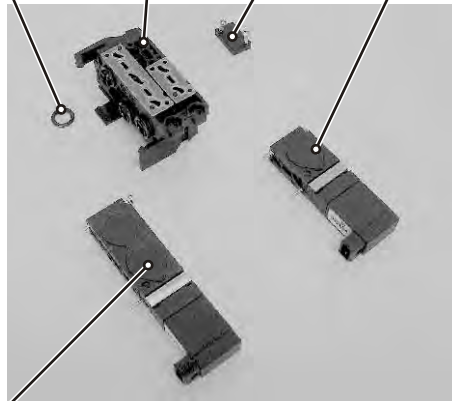

Ventil 5/2 Wege NC  
 valve 5/2 NC  
 1100500.05

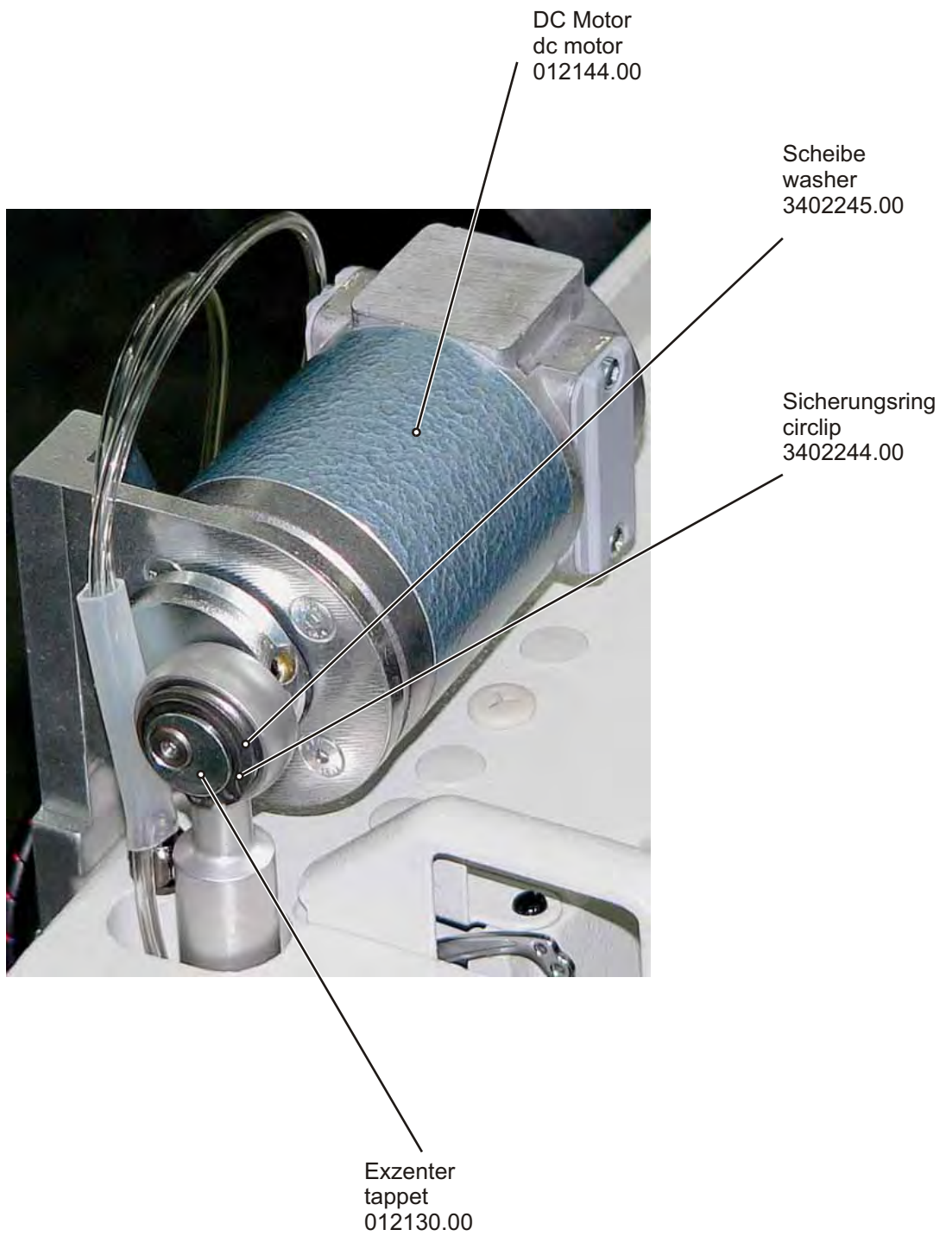

Magnetschalter  
magnetic switch  
012187.00

Gehäuse  
box  
2100667.00

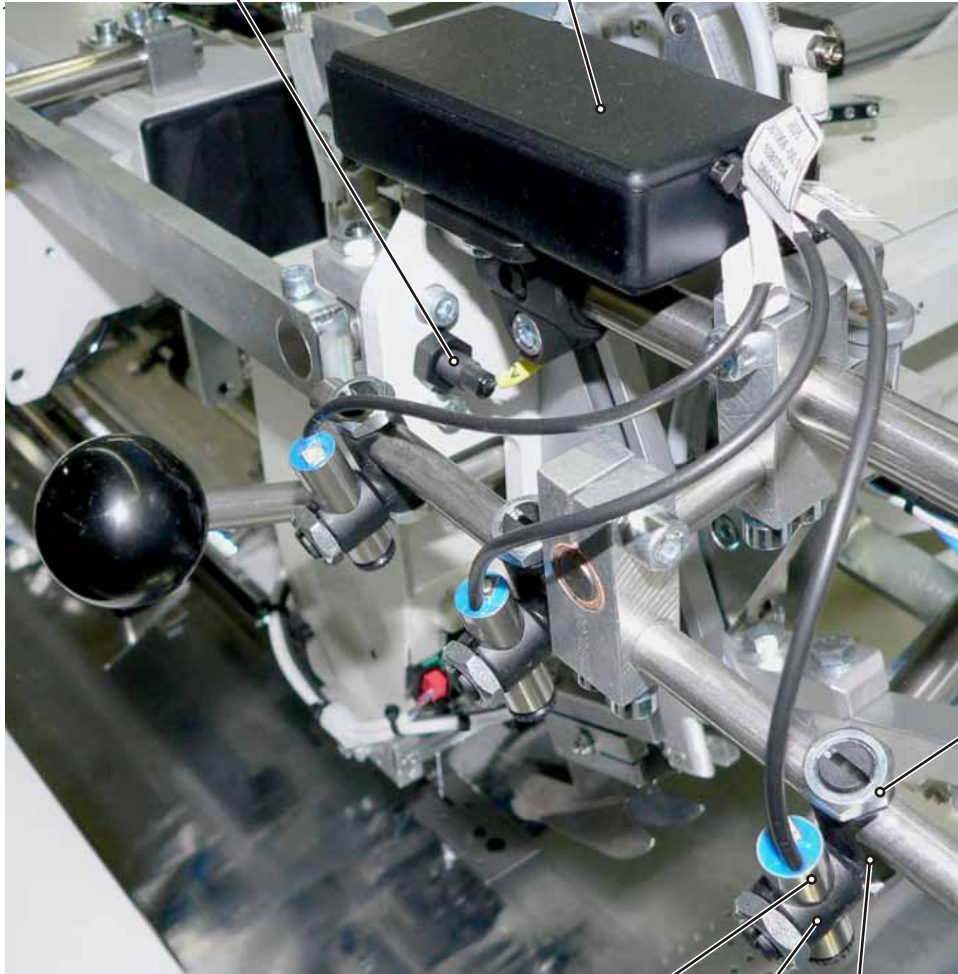

Mutter  
nut  
3402200.00

Laser  
laser  
2102067.00

Klemmstück  
clamping piece  
3402199.00

Klemmstück  
clamping piece  
3402198.00

Getriebemotor  
gear motor  
2400838.00

Zylinder + Abluftdrossel  
cylinder + throttle valve  
1000212.00 + 006927.00



Dämpfring  
damp ring  
011915.00

Achse  
shaft  
011917.00

Rad  
wheel  
011916.00



Ventil  
valve  
1100199.00



Sensor  
sensor  
2100753.10

Luftschlauch  
air hose  
1200240.12

Magnetschalter + Befestigung  
magnetic switch + mounting  
012222.01 + 1000144.10

Winkelverschraubung  
screw joint  
1400345.00



Zylinder  
cylinder  
1000242.00

Stempel  
punch  
008489.00

Abluftdrossel  
throttle valve  
006927.00

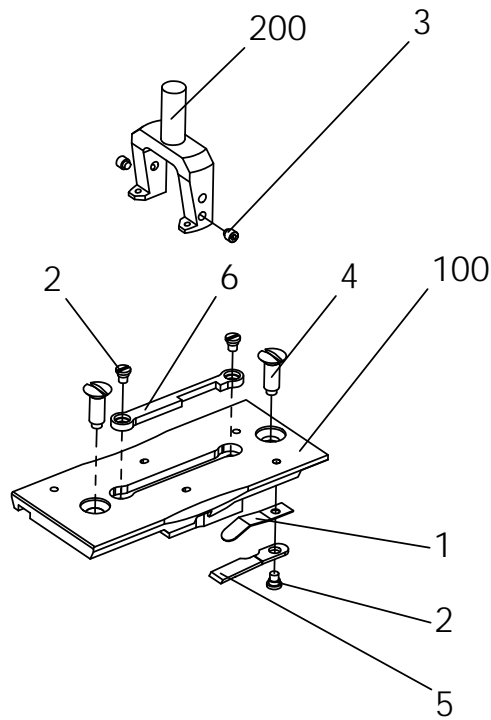

NR. No.	STÜCK PIECE	ARTIKEL NR. ARTICLE NO.	BEZEICHNUNG	NAME
1	2	008452-00	Blattfeder	leaf spring
2	4	3400106.00	Schraube	screw
3	2	3402119.00	Gewindestift	set screw
4	2	3400105.00	Schraube	screw
5	2	3400101.00	Messer	knife
6	1	3400107.00	Messer	knife
100	1	008494-00	Stichplatte NA 8	stitch plate needle distance 8mm
	1	008493-00	Stichplatte NA 10	stitch plate needle distance 10mm
	1	008425-00	Stichplatte NA 12	stitch plate needle distance 12mm
	1	008730-00	Stichplatte NA 14	stitch plate needle distance 14mm
	1	008743-00	Stichplatte NA 16	stitch plate needle distance 16mm
	1	008848-00	Stichplatte NA 18	stitch plate needle distance 18mm
	1	008737-00	Stichplatte NA 20	stitch plate needle distance 20mm
	1	008674-00	Stichplatte NA 22	stitch plate needle distance 22mm
	1	009564-00	Stichplatte NA 24	stitch plate needle distance 24mm
	1	010542-00	Stichplatte NA 26	stitch plate needle distance 26mm
	1	010461-00	Stichplatte NA 30	stitch plate needle distance 30mm
200	1	009124-00	Nadelhalter NA 8	needle holder , distance 8mm
	1	008766-00	Nadelhalter NA 10	needle holder , distance 10mm
	1	008673-00	Nadelhalter NA 12	needle holder , distance 12mm
	1	008678-00	Nadelhalter NA 14	needle holder , distance 14mm
	1	008742-00	Nadelhalter NA 16	needle holder , distance 16mm
	1	009157-00	Nadelhalter NA 18	needle holder , distance 18mm
	1	008738-00	Nadelhalter NA 20	needle holder , distance 20mm
	1	008675-00	Nadelhalter NA 22	needle holder , distance 22mm
	1	009563-00	Nadelhalter NA 24	needle holder , distance 24mm
	1	010543-00	Nadelhalter NA 26	needle holder , distance 26mm
	1	010460-00	Nadelhalter NA 30	needle holder , distance 30mm

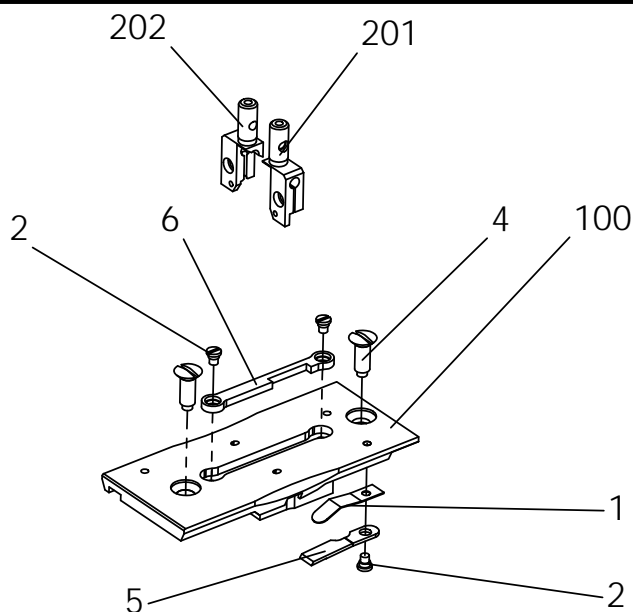

NR. No.	STÜCK PIECE	ARTIKEL NR. ARTICLE NO.	BEZEICHNUNG	NAME
1	2	008452-00	Blattfeder	leaf spring
2	4	3400106.00	Schraube	screw
3				
4	2	3400105.00	Schraube	screw
5	2	3400101.00	Messer	knife
6	1	3400107.00	Messer	knife
100	1	008494-00	Stichplatte NA 8	stitch plate needle distance 8mm
	1	008493-00	Stichplatte NA 10	stitch plate needle distance 10mm
	1	008425-00	Stichplatte NA 12	stitch plate needle distance 12mm
	1	008730-00	Stichplatte NA 14	stitch plate needle distance 14mm
	1	008743-00	Stichplatte NA 16	stitch plate needle distance 16mm
	1	008848-00	Stichplatte NA 18	stitch plate needle distance 18mm
	1	008737-00	Stichplatte NA 20	stitch plate needle distance 20mm
	1	008674-00	Stichplatte NA 22	stitch plate needle distance 22mm
	1	009564-00	Stichplatte NA 24	stitch plate needle distance 24mm
	1	010542-00	Stichplatte NA 26	stitch plate needle distance 26mm
	1	010461-00	Stichplatte NA 30	stitch plate needle distance 30mm
201	1	3400608.01	Nadelhalter rechts NA 8	needle holder , right, distance 8mm
	1	3400610.01	Nadelhalter rechts NA 10	needle holder , right, distance 10mm
	1	3400612.01	Nadelhalter rechts NA 12	needle holder , right, distance 12mm
	1	3400614.01	Nadelhalter rechts NA 14	needle holder , right, distance 14mm
	1	3400616.01	Nadelhalter rechts NA 16	needle holder , right, distance 16mm
	1	3400618.01	Nadelhalter rechts NA 18	needle holder , right, distance 18mm
	1	3400620.01	Nadelhalter rechts NA 20	needle holder , right, distance 20mm
	1	3400624.01	Nadelhalter rechts NA 24	needle holder , right, distance 24mm
	1	3400626.01	Nadelhalter rechts NA 26	needle holder , right, distance 26mm
	1	3400630.01	Nadelhalter rechts NA 30	needle holder , right, distance 30mm
202	1	3400608.02	Nadelhalter links NA 8	needle holder , left, distance 8mm
	1	3400610.02	Nadelhalter links NA 10	needle holder , left, distance 10mm
	1	3400612.02	Nadelhalter links NA 12	needle holder , left, distance 12mm
	1	3400614.02	Nadelhalter links NA 14	needle holder , left, distance 14mm
	1	3400616.02	Nadelhalter links NA 16	needle holder , left, distance 16mm
	1	3400618.02	Nadelhalter links NA 18	needle holder , left, distance 18mm
	1	3400620.02	Nadelhalter links NA 20	needle holder , left, distance 20mm
	1	3400624.02	Nadelhalter links NA 24	needle holder , left, distance 24mm
	1	3400626.02	Nadelhalter links NA 26	needle holder , left, distance 26mm
	1	3400630.02	Nadelhalter links NA 30	needle holder , left, distance 30mm

007399.00

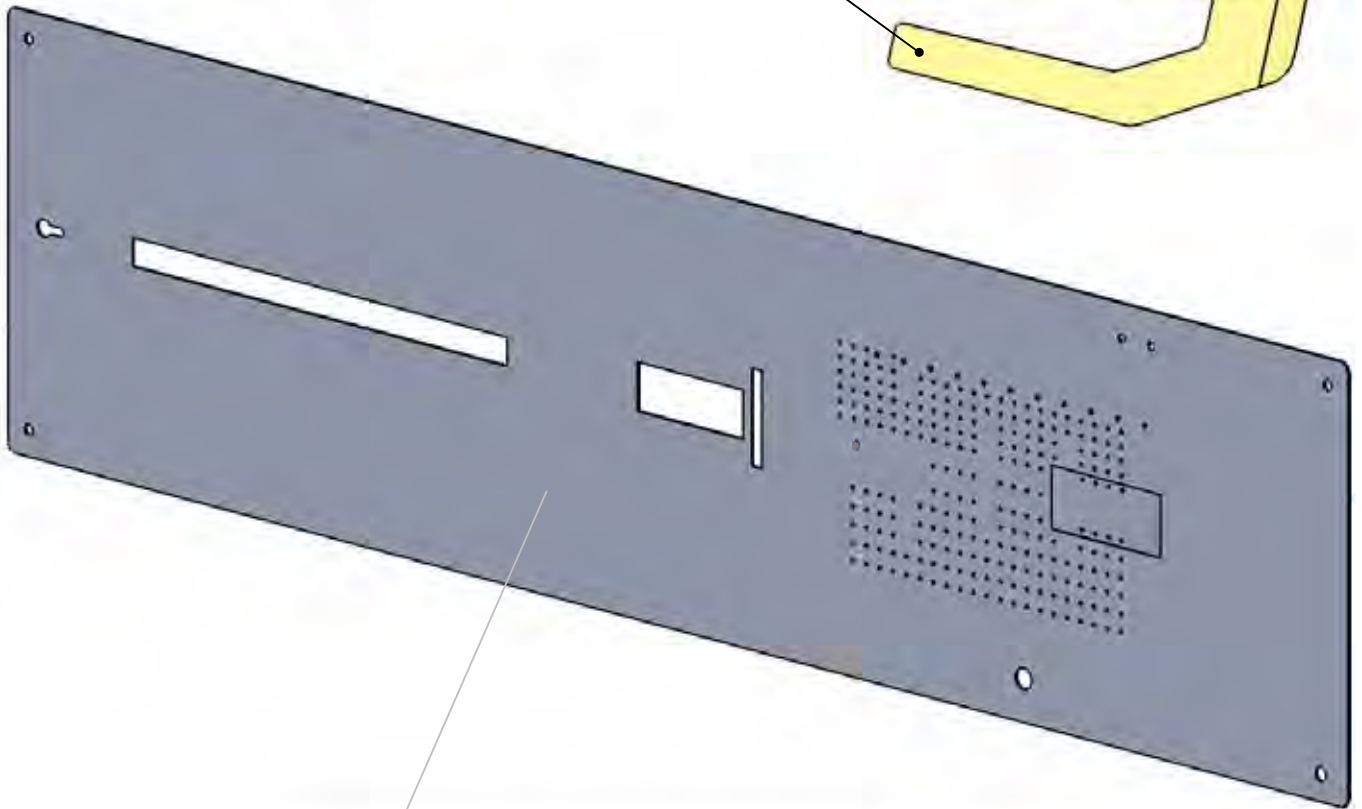
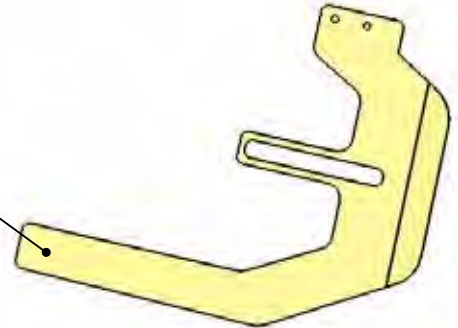

Teil Nr. part no.	Nadel Abstand needle distance	Ausführung version
011891.12	8-12mm	
011891.12.01	8-12mm	with vylene / mit Vlies
011891.16	14-16mm	
011891.16.01	14-16mm	with vylene / mit Vlies
011891.20	18-20mm	
011891.20.01	18-20mm	with vylene / mit Vlies
011891.24	22-24mm	
011891.26	26mm	
011891.30	30mm	

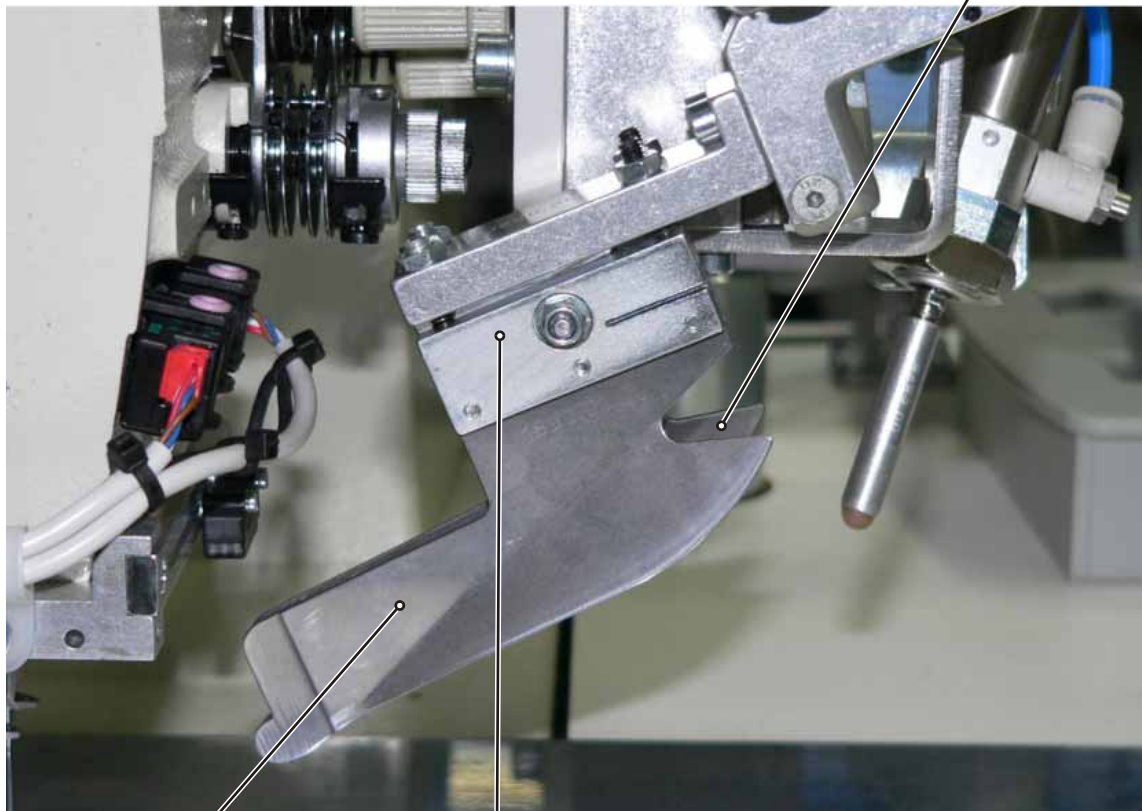

011899.01

011899.02

**Führungskopf Standard**  
**Führungsblechhalter    Führungsblechhalter**

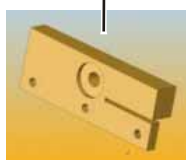

NA8	007557.00	007808.00
NA10	007557.00	007808.00
NA12	007557.00	007808.00
NA14	007679.00	007809.00
NA16	007679.00	007809.00
NA18	008116.00	008117.00
NA20	008116.00	008117.00
NA22	007911.00	007912.00
NA24	007911.00	007912.00
NA26	010540.00	010541.00
NA30	010465.00	010466.00

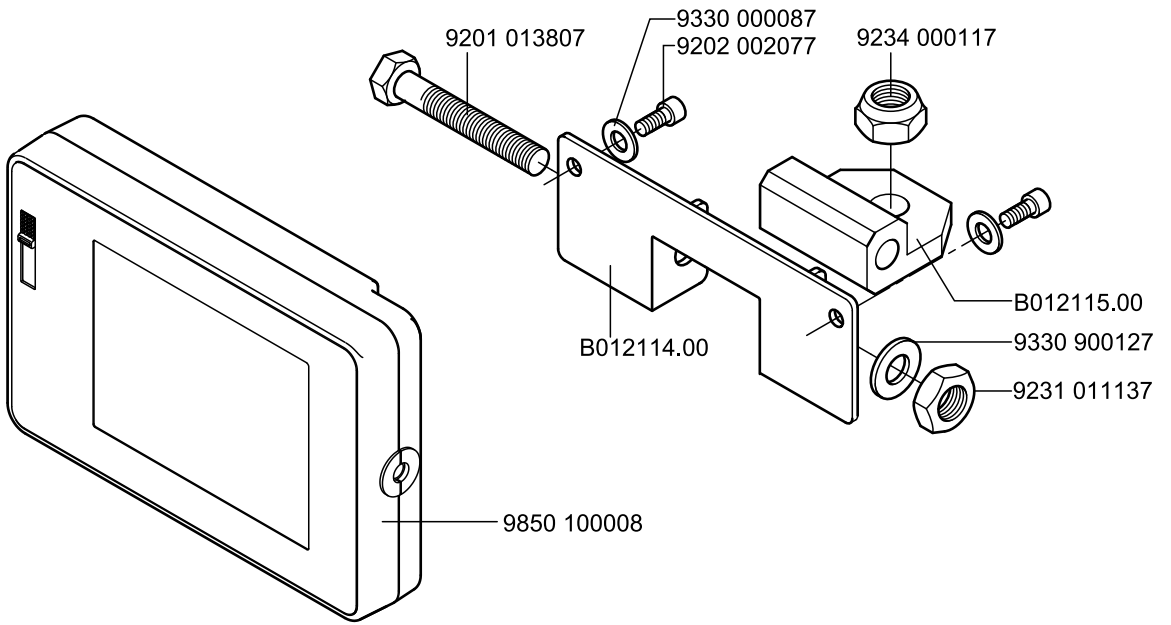

USB - Stick  
USB - stick  
2102060.00

Bedienfeld  
touch screen  
47.100/68.20

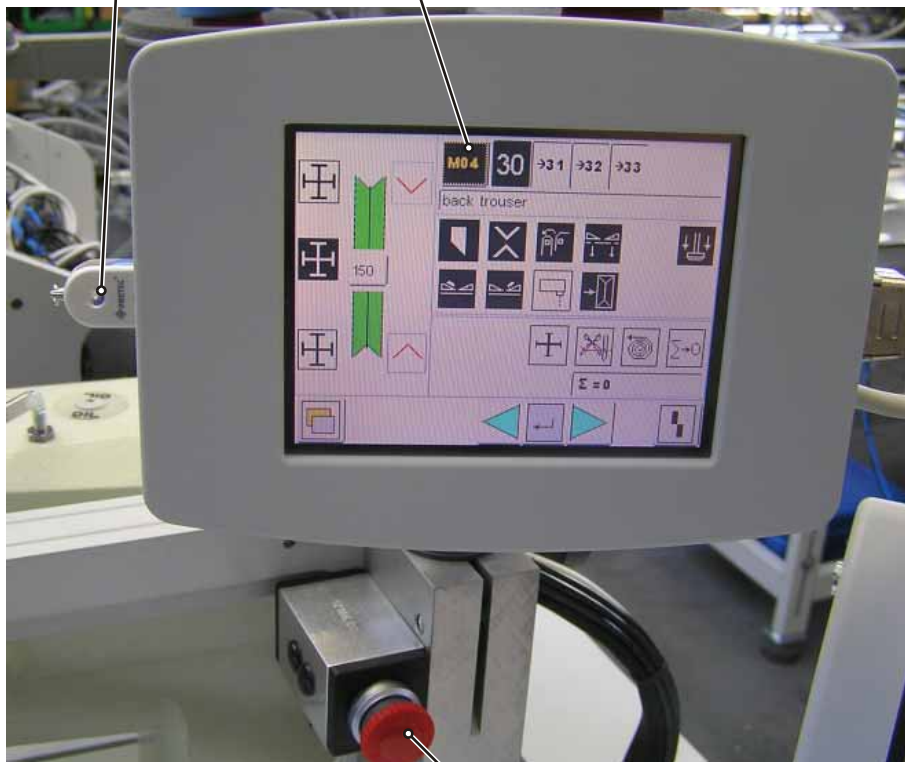

Kontaktelement  
contact element  
2100760.00



Magnetschalter  
magnetic switch  
012149.00

Ringmagnet  
ring magnet  
2102069.02

Paspelführung  
piping guide  
011897.00

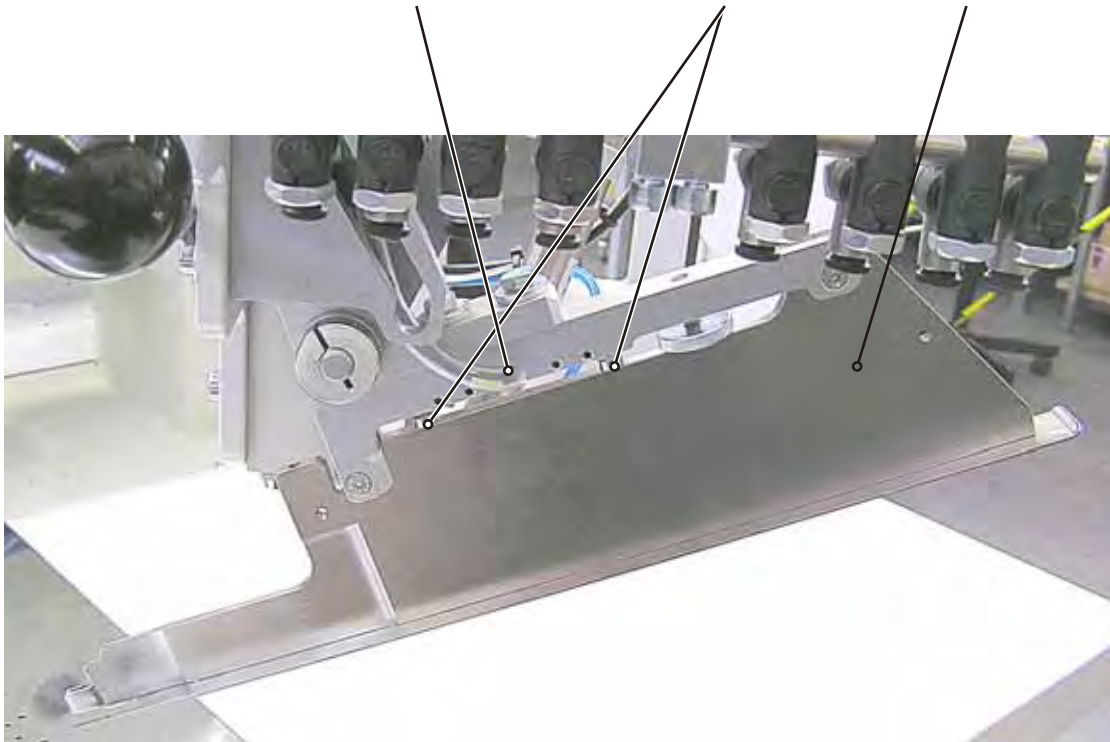

**Sohlen 100/68 Standard**

**Doppel-Paspel    Leiste Hose    Leiste Sakko**

8mm	007609.00	007610.00	007611.00
10mm	007612.00	007613.00	007614.00
12mm	007597.00	007598.00	007599.00
14mm	007615.00	007616.00	007617.00
16mm	007618.00	007619.00	007620.00
18mm	007621.00	007622.00	007623.00
20mm	007624.00	007625.00	007626.00
22mm	007627.00	007628.00	007629.00
24mm	007630.00	007632.00	007631.00
26mm	010547.00	010546.00	010545.00
30mm	010462.00	010464.00	010463.00

**Sohlen 100/68 Brustleistenverarbeitung**

**Doppel-Paspel    Leiste Paspel**

10mm	009155.00	009421.00
12mm	009125.00	009420.00
14mm	010469.00	010467.00

**Sohlen 100/68 Nahtlänge 240mm**

**Doppel-Paspel    Leiste Hose    Leiste Sakko**

8mm			
10mm	010492.00	010493.00	010494.00
12mm	008853.00	008852.00	008851.00
14mm	010230.00	010231.00	010468.00
16mm	011015.00	011014.00	011013.00
18mm			
20mm	010004.00	010005.00	010006.00
22mm	010803.00	010804.00	010805.00
24mm	010453.00	010455.00	010454.00
26mm			
30mm			

Magnetschalter M8  
magnetic switch  
012187.00

Halter  
holder  
011841.00

Abluftdrossel  
throttle valve  
006927.00

Zylinder  
cylinder  
1000508.00

Führung  
rail guide  
1500553.00



Magnetschalter  
magnetic switch  
012222.01

Bock  
holding device  
011843.00

Hebel  
lever  
012055.00

Gelenkkopf  
swivel head  
1500391.00

Befestigung  
mounting  
1000508.10

Zahnriemen  
toothed belt  
2500802.06

Segmentscheibe  
segment disc  
011876.00

Lichtschranke  
light barrier  
2102064.00

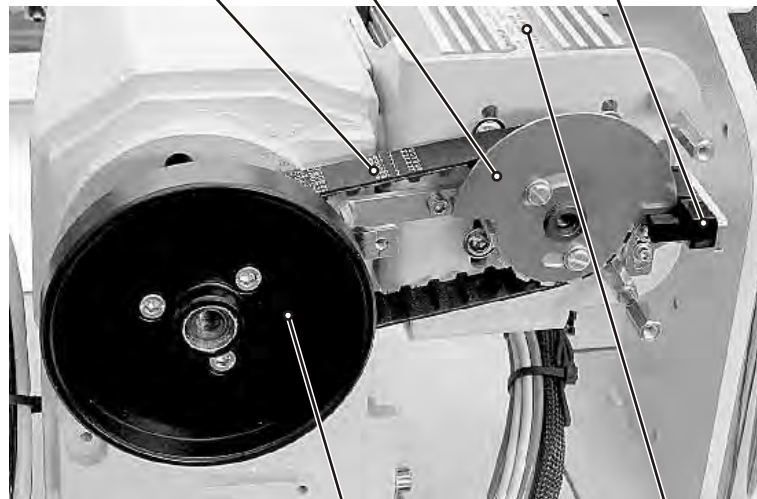

Handrad  
hand wheel  
011873.00

Motor  
motor  
2400837.00

Schaltelement  
switching element  
2500910.01

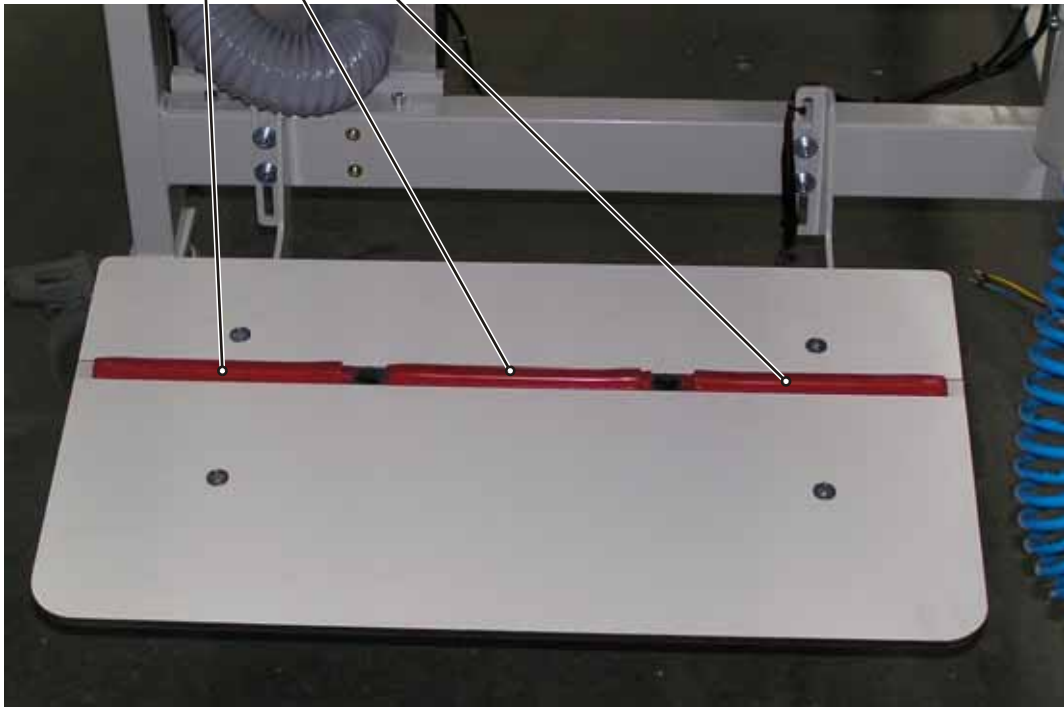

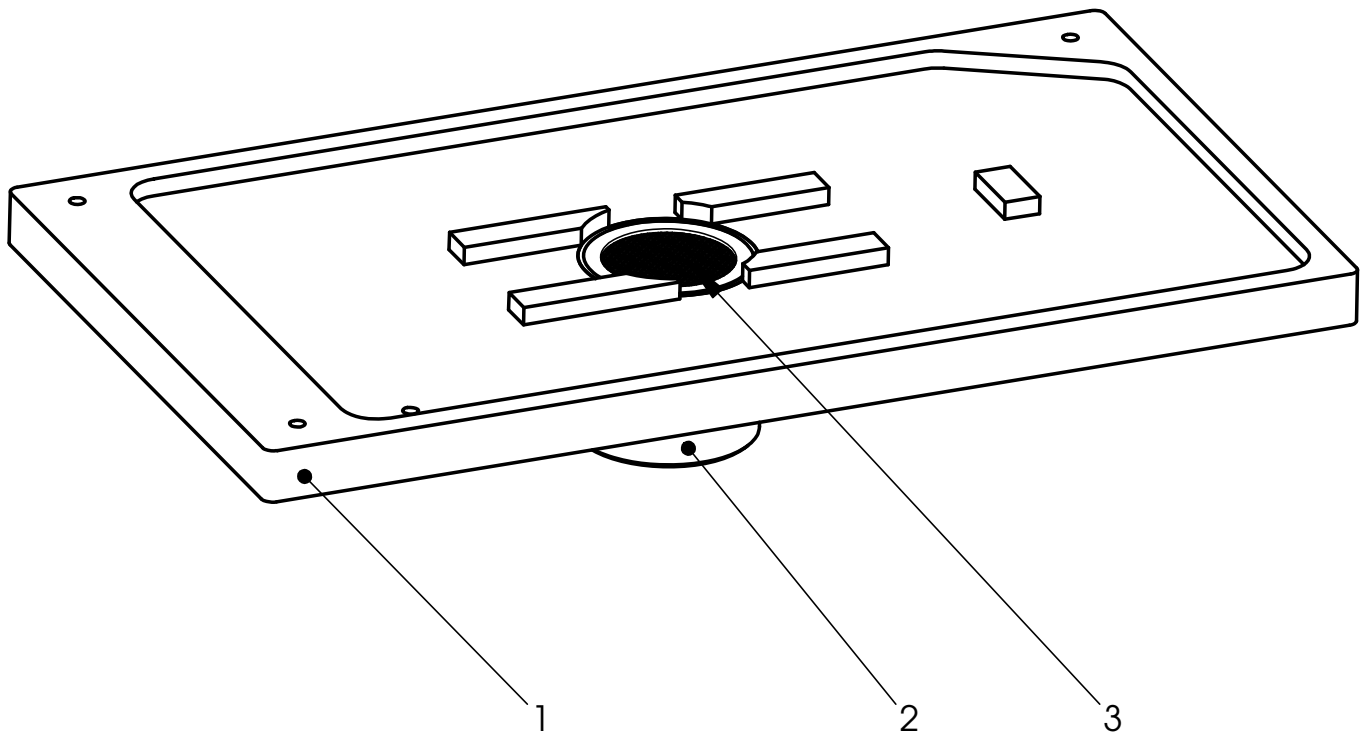

NR. No.	STÜCK PIECE	TEILENR.	Bezeichnung	Name
1	1	012275-00	Vakuumpalte	vacuum plate
2	1	012351-00	Vacuumanfchluf	vacuum connection
3	1	007266-00	Sieb	filter

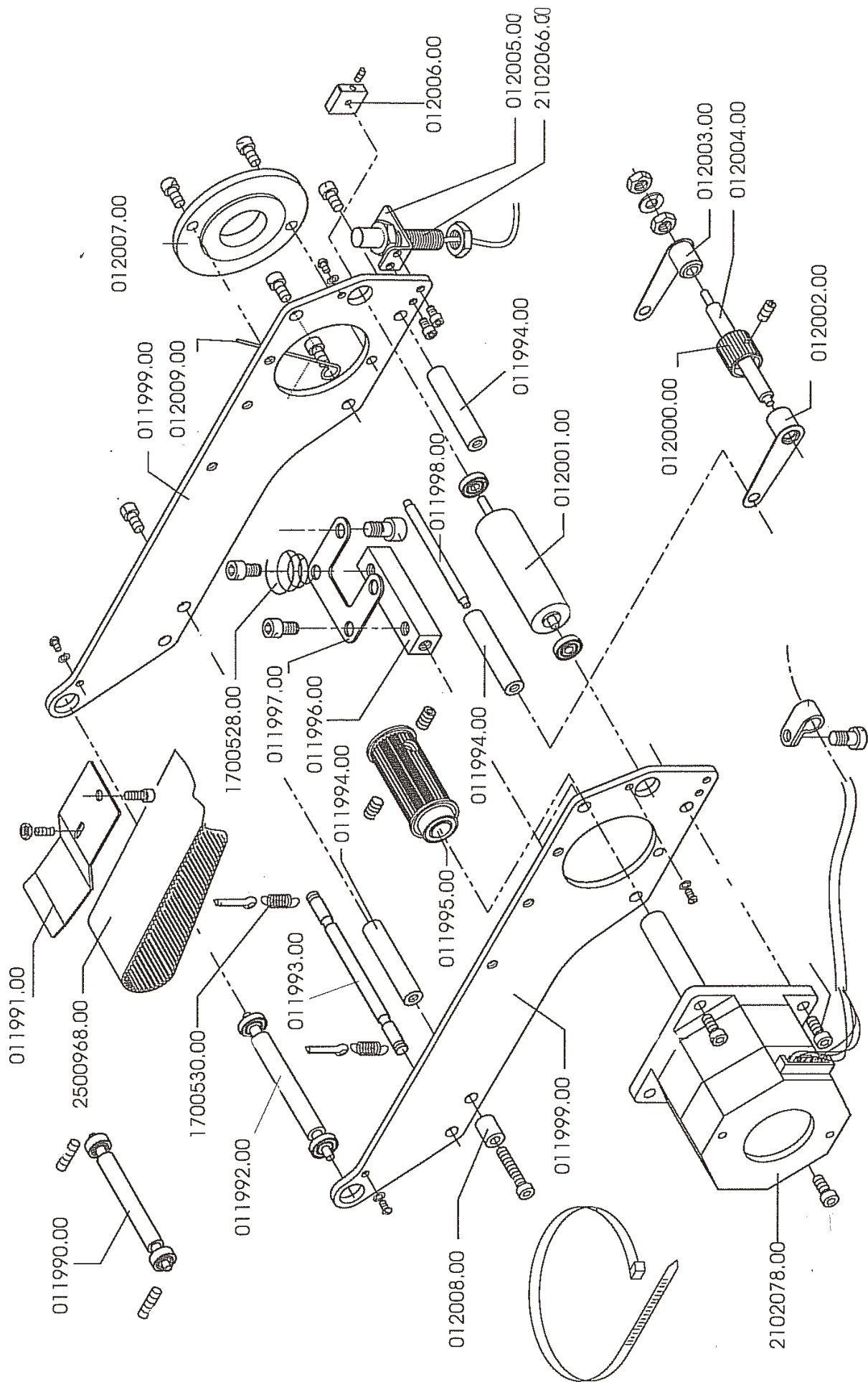

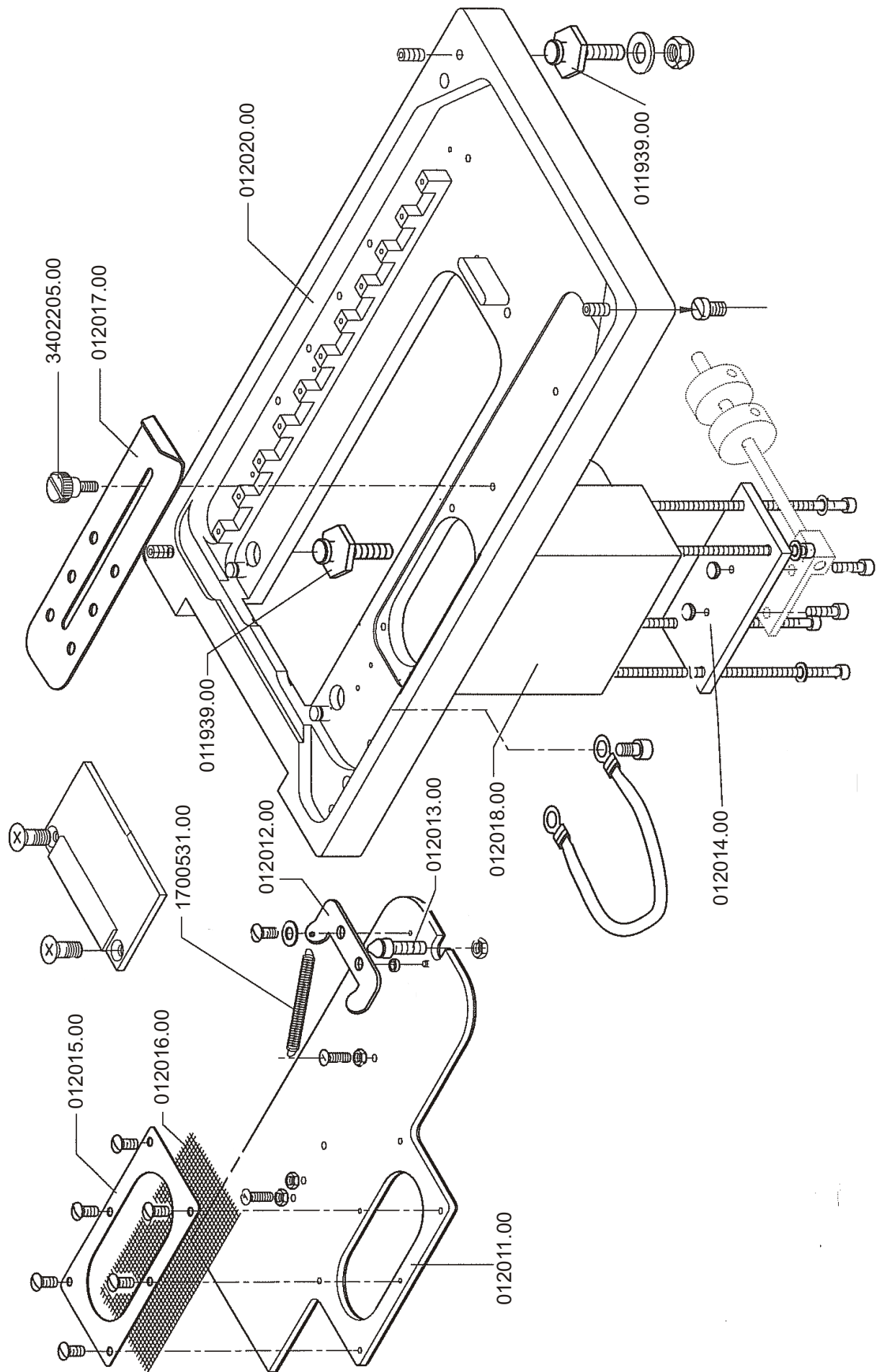

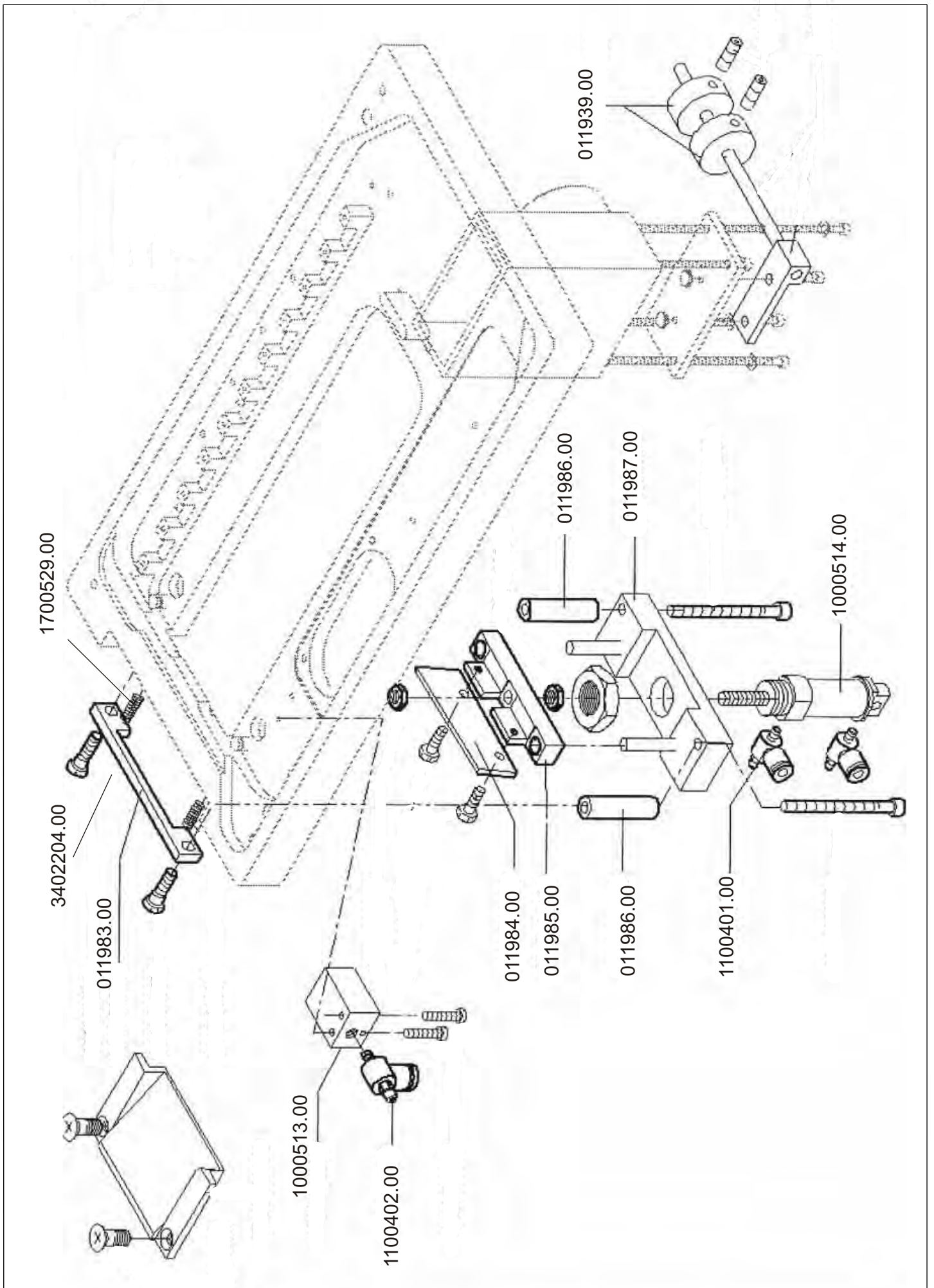



H1 . カマ関係 / Rotary hook mechanism / Greifervorrichtung / Mécanisme du crochet rotatif / Mecanismo del cangrejo

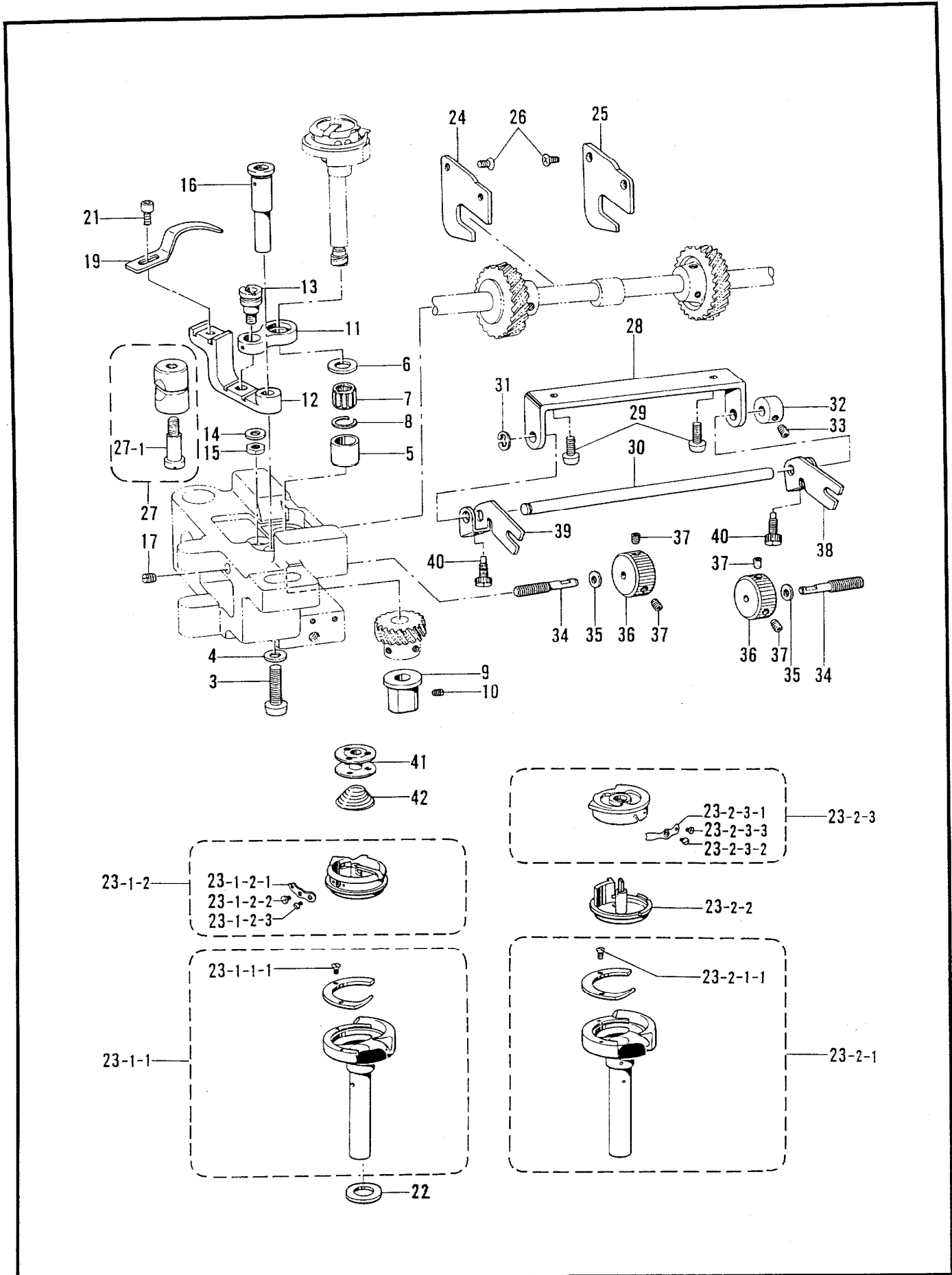

H1 . カマ関係 / Rotary hook mechanism / Greifervorrichtung / Mécanisme du crochet rotatif / Mecanismo del cangrejo

REF.NO.	CODE	Q'TY	ヒンメイ	NAME OF PARTS	RM
3	062782512	2	ナベコ635-28X25	SCREW, PAN SM6.35-28X25	
4	100197002	2	ザガネ	WASHER	
5	S07418001	2	カマジクメタルU	ROTARY HOOK SHAFT BUSH (U)	
6	S07421001	2	スラストリング	THRUST RING	
7	S07420000	2	ニードルベアリング	NEEDLE BEARING	
8	S07419001	2	ストツプリング	STOP RING	
9	S07417001	2	カマジクメタルD	ROTARY HOOK SHAFT BUSH (D)	
10	013710512	2	トメネジ4.76クボミ	SET SCREW, (CP) SM4.76	
11	112692101	2	オープナーリンク	OPENER LINK	
12	S38211051	2	オープナーレバー	OPENER LEVER	
13	148005001	2	オープナーリンクジク	OPENER LINK SHAFT	
14	025710232	2	ヒラザガネチユウ4.76	WASHER, PLAIN M 4.76	
15	110161006	2	ナツト4.76	NUT, SM4.76	
16	S13021001	2	オープナーレバージク	OPENER LEVER SHAFT	
17	013711012	2	トメネジ4.76クボミ	SET SCREW, (CP) SM4.76	
19	S38212001	2	オープナー	OPENER	
20	105161002	2	ザガネ	WASHER	
21	154965001	2	アナボルト3.57X8	BOLT, SOCKET SM3.57X8	
21	062670812	2	<ファンデーション仕様> ナベコ3.57-40X8	<FOR FOUNDATION SPEC.> SCREW, PAN SM3.57-40X8	
24	S07436001	1	ギヤアンナイL	GEAR GUIDE (L)	
25	S07437001	1	ギヤアンナイR	GEAR GUIDE (R)	
26	108960002	4	サラネジ3.57	SCREW, FLAT SM3.57	
27	S07658001	2	ピンチスリーブクミ	PINCH SLEEVE ASSY	
27-1	112700001	2	シメネジ5.95	SCREW, SM5.95	
28	S07430001	1	ハリスキチヨウセツボウササエ	ADJUST BAR SUPPORT	
29	062711012	2	ナベコ476-32X10	SCREW, PAN SM4.76-32X10	
30	S07431001	1	ハリスキチヨウセツボウ	ADJUST BAR	
31	048040342	1	トメワE4	RETAINING RING, E4	
32	159436001	1	セツトカラー	SET SCREW COLLAR	
33	014680622	1	アナトメネジ4.37クボミ	SET SCREW, SOCKET (CP) SM4.37	
34	S07434101	2	ハリスキチヨウセツネジ	ROTARY HOOK BASE ADJUST SCREW	
35	025680132	2	ヒラザガネシヨウ4.37	WASHER, PLAIN S 4.37	
36	S07435001	2	ハリスキチヨウセツナツト	ROTARY HOOK BASE ADJUST DIAL	
37	014680622	4	アナトメネジ4.37クボミ	SET SCREW, SOCKET (CP) SM4.37	
38	S34435001	1	ハリスキチヨウセツフタマタR	PRESET LEVER (R)	
39	S34436001	1	ハリスキチヨウセツフタマタL	PRESET LEVER (L)	
40	131226001	2	ハリトメネジ3.57	NEEDLE SET SCREW, SM3.57	
41	112781101	2	<スタンダード用> ボビン	<FOR STANDARD> BOBBIN, ST	
22	153243001	4	<糸切り用> スペーサー0.2	<FOR THREAD TRIMMER> SPACER, 0.2	
22	153244001	2	スペーサー0.3	SPECER, 0.3	
41	S01928101	2	ボビン	BOBBIN, TR	
42	148602001	2	クウテンボウシバネ	BOBBIN TENSION SPRING	

H2 . カマ関係 / Rotary hook mechanism / Greifervorrichtung / Mécanisme du crochet rotatif / Mecanismo del cangrejo

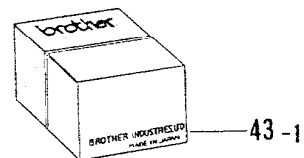
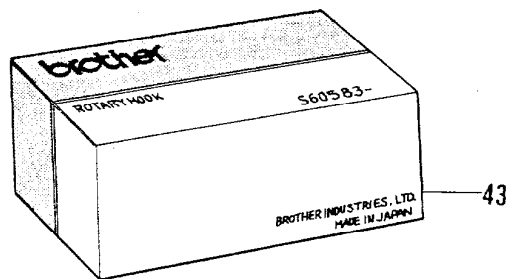
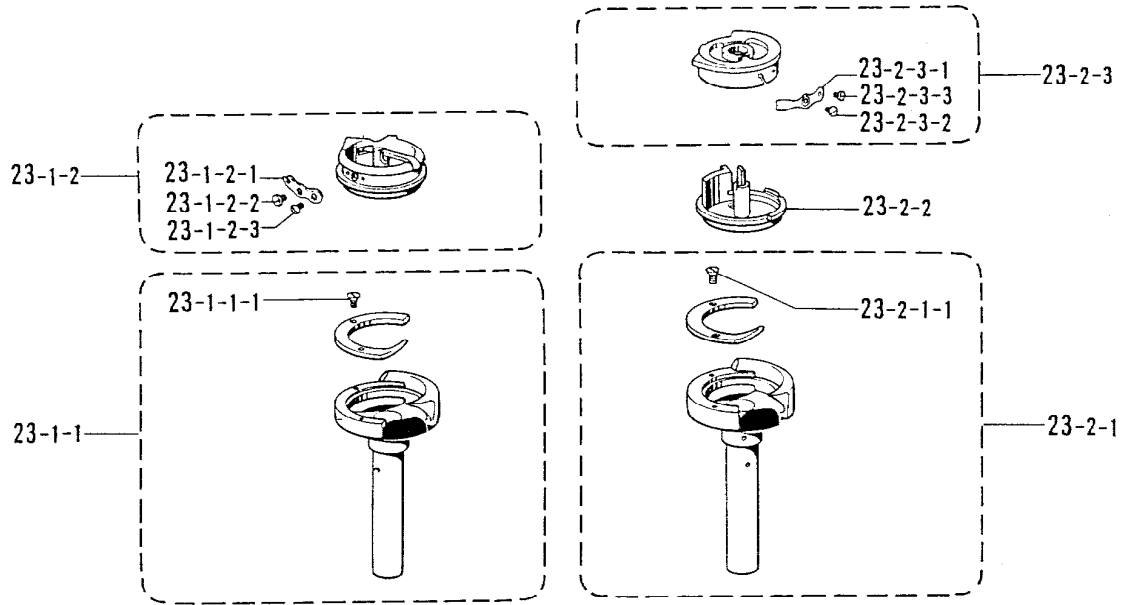

H2 . カマ関係 / Rotary hook mechanism / Greifervorrichtung / Mécanisme du crochet rotatif / Mecanismo del cangrejo

REF.NO.	CODE	Q'TY	ヒンメイ	NAME OF PARTS	RM
23-1	S07425001	2	<ST."-1","-3"用> ニホンハリカマ	<FOR STANDARD "-1","-3"> ROTARY HOOK ASSY (-3)	
23-1-1	S07731001	2	ソトカマクミ	OUTER ROTARY HOOK ASSY	
23-1-1-1	151022001	2	ウライタ	BACK PLATE	
23-1-1-2	151028001	4	ウライタトメネジ	SET SCREW	
23-1-1-3	151027001	4	ウチカマオサエトメネジ	INNER ROTARY HOOK SET SCREW	
23-1-2	S07735001	2	ウチカマクミ	INNER ROTARY HOOK ASSY	
23-1-2-1	151145001	2	チヨウシバネ	TENSION SPRING	
23-1-2-2	151029001	2	チヨウシネジ	TENSION ADJUST SCREW	
23-1-2-3	151030001	2	チヨウシバネトメネジ	SET SCREW	
23-1	S07426001	2	<ST."-5"用> ニホンハリカマ	<FOR STANDARD "-5"> ROTARY HOOK ASSY (-5)	
23-1-1	S07732001	2	ソトカマクミ	OUTER ROTARY HOOK ASSY	
23-1-2	S07736001	2	ウチカマクミ	INNER ROTARY HOOK ASSY	
23-1-2-1	151146001	2	チヨウシバネ	TENSION SPRING	
23-1	S07427001	2	<糸切り用> ニホンハリカマ	<FOR THREAD TRIMMER> ROTARY HOOK ASSY TR.	
23-1-1	S07733001	2	ソトカマクミ	OUTER ROTARY HOOK ASSY	
23-1-2	S07737001	2	ウチカマクミ	INNER ROTARY HOOK ASSY	
23-1-2-1	151145001	2	チヨウシバネ	TENSION SPRING	
23-2	S07428001	2	" ST. 用オプションパーツ " <-1,-3用 キャップ付蓋>	" OPTION PARTS FOR STANDARD " <"-1","-3" WITH CAP>	
23-2-1	S13611001	2	ニホンハリカマ	ROTARY HOOK ASSY (CAP)	
23-2-1-1	S07731001	2	カマクミ	ROTARY HOOK ASSY <CAP LESS>	
23-2-1-1-1	151022001	2	ソトカマクミ	OUTER ROTARY HOOK ASSY	
23-2-1-1-2	151028001	2	ウライタ	BACK PLATE	
23-2-1-1-3	151027001	4	ウライタトメネジ	SET SCREW	
23-2-1-2	151027001	4	ウチカマオサエトメネジ	INNER ROTARY HOOK SET SCREW	
23-2-1-2	S07738001	2	ウチカマクミ	INNER ROTARY HOOK ASSY	
23-2-2	S07740001	2	キャツブクミ	BOBBIN CASE ASSY	
23-2-2-1	154518001	2	チヨウシバネ	TENSION SPRING	
23-2-2-2	154519001	2	チヨウシネジ	ADJUST SCREW	
23-2-2-3	151030001	2	チヨウシバネトメネジ	SET SCREW	
23-1	S36981001	2	<オープン 給油蓋 -3用> ニホンハリカマ	<"-3" FOR JEANS> ROTARY HOOK ASSY (OP. -3)	
23-1-1	S36989001	2	ソトカマクミ	OUTER ROTARY HOOK ASSY	
23-1-2	S07735001	2	ウチカマクミ	INNER ROTARY HOOK ASSY	
23-1	S36982001	2	<オープン 給油蓋 -5用> ニホンハリカマ	<"-5" FOR JEANS> ROTARY HOOK ASSY (OP. -5)	
23-1-1	S36990001	2	ソトカマクミ	OUTER ROTARY HOOK ASSY	
23-1-2	S07736001	2	ウチカマクミ	INNER ROTARY HOOK ASSY	
23-1	S36994001	2	<剣先強化蓋 -1,-3用> ニホンハリカマ	<HOOK ASSY (HP) FOR "-1","-3"> ROTARY HOOK ASSY (HP) -3	
23-1-1	S36983001	2	ソトカマクミ	OUTER ROTARY HOOK ASSY	
23-1-2	S36985001	2	ウチカマクミ	INNER ROTARY HOOK ASSY, RP	
23-1	S36995001	2	<剣先強化RP蓋 -1,-3用> ニホンハリカマ	<HOOK ASSY (HP) & (RP) "-1","-3"> ROTARY HOOK ASSY (RP) -3	
23-1-1	S36984001	2	ソトカマクミ	OUTER ROTARY HOOK ASSY	
23-1-2	S36985001	2	ウチカマクミ	INNER ROTARY HOOK ASSY	
23-1	S37002001	2	" 糸切り用オプションパーツ " <剣先強化蓋>	" OPTION PARTS FOR THREAD TRIMMER " <HOOK ASSY (HP)>	
23-1-1	S37004001	2	ニホンハリカマ	ROTARY HOOK ASSY (HP) TR.	
23-1-2	S07737001	2	ソトカマクミ	OUTER ROTARY HOOK ASSY	
		2	ウチカマクミ	INNER ROTARY HOOK ASSY	

H3 . カマ関係 / Rotary hook mechanism / Greifervorrichtung / Mécanisme du crochet rotatif / Mecanismo del cangrejo

REF.NO.	CODE	Q'TY	品名	NAME OF PARTS	RM
23-2 23-2-1 23-2-1-1 23-2-1-2	S07429001 S13612001 S07734001 S07739001	2 2 2 2	"オプションパーツ" <糸切り用キャップ付蓋> ニホンハリカマ カマクミ ソトカマクミ ウチカマクミ	"OPTION PARTS" <FOR THREAD TRIMMER WITH CAP> ROTARY HOOK ASSY (CAP) TR. ROTARY HOOK ASSY <Capless> OUTER ROTARY HOOK ASSY INNER ROTARY HOOK ASSY	
43	S07425901	1	"スタンダード用補給パーツ" <-1,-3用> ニホンハリカマハコクミ	"SUPPLY PARTS FOR STANDARD" <FOR "-1","-3"> ROTARY HOOK BOX ASSY (-3)	
43 43-1	S07426901 S07732901	1 1	<-5用> ニホンハリカマハコクミ ソトカマクミハコクミ	<FOR "-5"> ROTARY HOOK BOX ASSY (-5) OUTER ROTARY HOOK BOX ASSY	
43	S36981901	1	<オープン給油蓋-3用> ニホンハリカマハコクミ	<"-3" FOR JEANS> ROTARY HOOK BOX ASSY (OP. -3)	
43	S36982901	1	<オープン給油蓋-5用> ニホンハリカマハコクミ	<"-5" FOR JEANS> ROTARY HOOK BOX ASSY (OP. -5)	
43	S36994901	1	<剣先強化蓋-1,-3用> ニホンハリカマハコクミ	<HOOK ASSY (HP) FOR "-1","-3"> ROTARY HOOK BOX ASSY (HP) -3	
43 43-1	S36995901 S36985901	1 1	<剣先強化RP蓋-1,-3用> ニホンハリカマハコクミ ウチカマクミハコクミ	<HOOK ASSY (HP) & (RP) FOR "-1","-3"> ROTARY HOOK BOX ASSY (RP) -3 INNER ROTARY HOOK BOX ASSY (RP)	
43 43-1	S07428901 S13611901	1 1	<キャップ付蓋-1,-3用> ニホンハリカマハコクミ カマクミハコクミ	<FOR "-1","-3" WITH CAP> ROTARY HOOK BOX ASSY (CAP) ROTARY HOOK BOX ASSY <Capless>	
43	S07427901	1	"糸切り用補給パーツ" <標準部品> ニホンハリカマハコクミ	"SUPPLY PARTS FOR THREAD TRIMMER" <FOR STANDARD PARTS> ROTARY HOOK BOX ASSY TR.	
43	S37002901	1	<剣先強化蓋> ニホンハリカマハコクミ	<HOOK ASSY (HP) > ROTARY HOOK BOX ASSY (HP) TR.	
43 43-1	S07429901 S13612901	1 1	<キャップ付蓋> ニホンハリカマハコクミ カマクミハコクミ	<HOOK ASSY WITH CAP> ROTARY HOOK BOX ASSY (CAP) TR. ROTARY HOOK BOX ASSY, TR <Capless>	

N. 糸切り関係 (糸切り) / Thread trimmer mechanism (Thread Trimmer)  
 / Fadenabschneidevorrichtung (Fadenabschneider) / Mécanisme de coupe-fil (Coupe-fil)  
 / Mecanismo de la cortadura de hiros (Cortahilos)

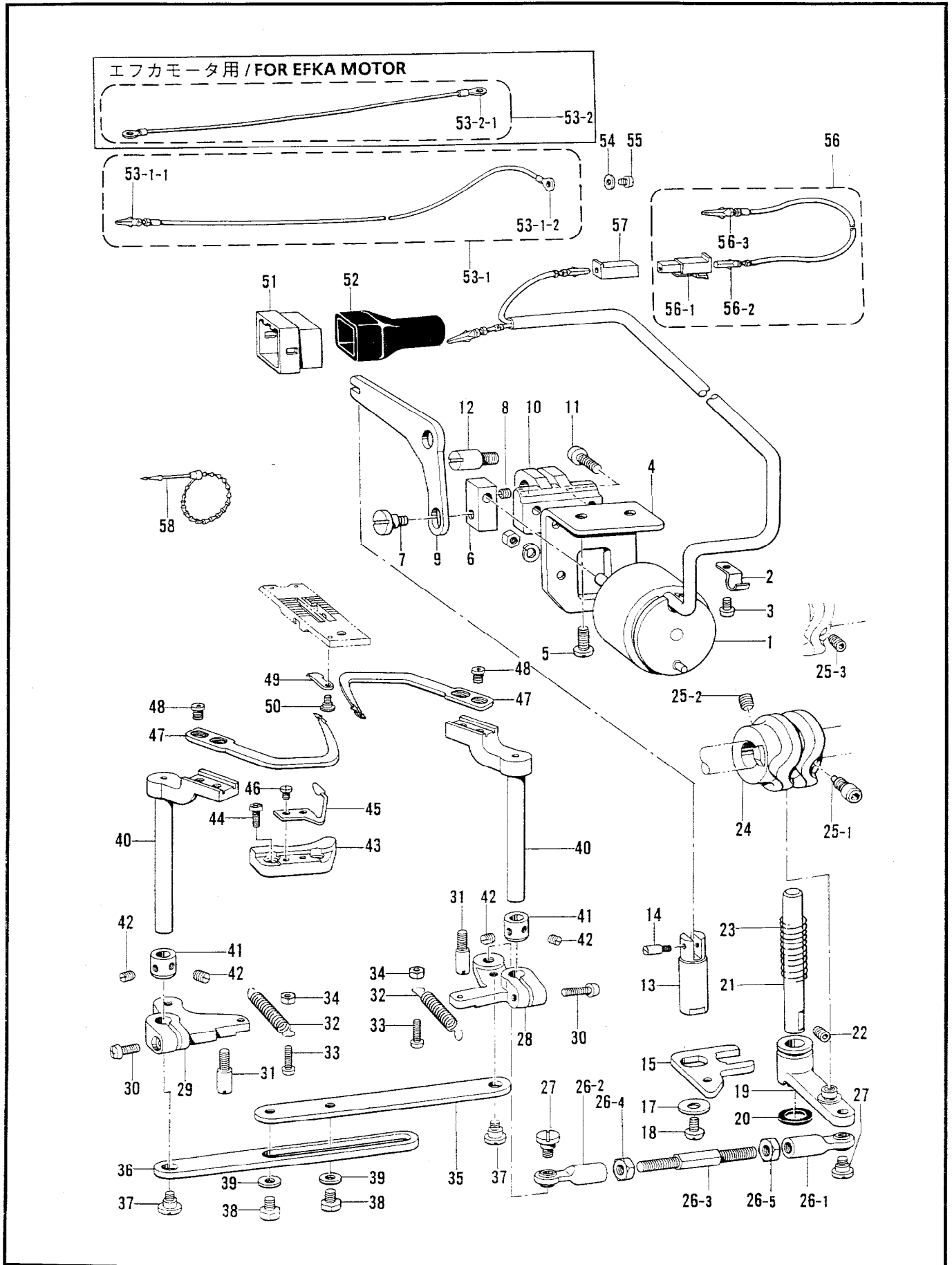

N. 糸切り関係 (糸切り) / Thread trimmer mechanism (Thread Trimmer)  
 / Fadenabschneidevorrichtung (Fadenabschneider) / Mécanisme de coupe-fil (Coupe-fil)  
 / Mecanismo de la cortadura de hiros (Cortahilos)

REF.NO.	CODE	Q'TY	ヒンメイ	NAME OF PARTS	RM
1	S18884009	1	<DCモータ用> イトキリソレノイド	<FOR DC MOTOR> THREAD TRIMMER SOLENOID	
1	S07495009	1	<エフカモータ用> _____	<FOR EFKA MOTOR> THREAD TRIMMER SOLENOID	
2	140647001	1	コードオサエ	CORD HOLDER	
3	062670512	1	ナベコ357-40X5	SCREW, PAN SM3.57-40X5	
4	S07496001	1	ソレノイドシジイタ	THREAD TRIM. SOL. BRACKET	
5	110201001	2	シメネジ6.35	SCREW, SM6.35	
6	S07497101	1	ソレノイドツギテ	THREAD TRIMMING SOLENOID JOINT	
7	144526001	1	ダンネジ4.37	SHOULDER SCREW, SM4.37	
8	014680622	1	アナトメネジ4.37クボミ	SET SCREW, SOCKET (CP) SM4.37	
9	S07498001	1	ソレノイドレバー	THREAD TRIMMING SOLENOID LEVER	
10	S07499001	1	ソレノイドレバーウケ	THR. TRIM. SOL. LEVER BRACKET	
11	062711012	2	ナベコ476-32X10	SCREW, PAN SM4.76-32X10	
12	S07500001	1	ソレノイドレバージク	THREAD TRIM. SOL. LEVER STUD	
13	S07501001	1	イトキリジク	THREAD TRIMMING DRIVING ROD	
14	148546001	1	プランジャピン	PLUNGER PIN	
15	S07502101	1	イトキリジクイタ	THR. TRIM. DRIVING ROD PLATE	
17	116662003	1	ザガネ	WASHER	
18	062711012	1	ナベコ476-32X10	SCREW, PAN SM4.76-32X10	
19	S34444001	1	シユレバークミ	KNIFE MAIN LEVER SHAFT	
20	148559100	1	ゴム	RUBBER	
21	S07508001	1	シユレバークミ	KNIFE MAIN LEVER SHAFT	
22	014781032	1	アナクボミ635-28X10	SET SCREW, SOCKET (CP) SM6.35	
23	S07509001	1	シユレバークミ	SPRING, COMPRESSION	
24	S07510001	1	イトキリカム	THREAD TRIMMING CAM	
25-1	148574001	1	<一般用> セットネジ6.35	<FOR GENERAL USE> SET SCREW, SOCKET SM6.35	
25-2	014771022	1	アナトメネジ6.35クボミ	SET SCREW, SOCKET (CP) SM6.35	
25-3	014771022	2	<-1用> アナトメネジ6.35クボミ	<FOR "-1" > SET SCREW, SOCKET (CP) SM6.35	
26	S07511001	1	ナガサチヨウセツレンカンクミ	LENG. ADJ. CONNECTING ROD ASSY	
26-1	S07512001	1	タマツギテRクミ	ROUND JOINT (R) ASSY	
26-2	S07514001	1	タマツギテLクミ	ROUND JOINT (L) ASSY	
26-3	S07516001	1	ナガサチヨウセツレンカン	LENGTH ADJUST CONNECTING ROD	
26-4	148592001	1	ナツト5.95	NUT, SM5.95	
26-5	100022005	1	ナツト5.95	NUT, SM5.95	
27	141494001	2	タマツギテダンネジ	SHOULDER SCREW	
28	S38419001	1	イトキリレバーR	THREAD TRIMMING LEVER (R)	
29	S38420001	1	イトキリレバーL	THREAD TRIMMING LEVER (L)	
30	062681212	2	ナベコ437-40X12	SCREW, PAN SM4.37-40X12	
31	S07519001	2	ストツパーネジ4.76	STOPPER SCREW, SM4.76	
32	S07520001	2	イトキリレバークミ	SPRING, EXTENSION	
33	062671412	2	ナベコ357-40X14	SCREW, PAN SM3.57-40X14	
34	021670102	2	ナツト1シユ3.57	NUT, 1 SM3.57	
35	S07521001	1	イトキリレンカンR	THR. TRIM. CONNECTING ROD (R)	
36	S07522001	1	イトキリレンカンL	THR. TRIM. CONNECTING ROD (L)	
37	144526001	2	ダンネジ4.37	SHOULDER SCREW, SM4.37	
38	146360002	2	ボルト4.76X7	BOLT, SM4.76X7	
39	025710232	2	ヒラザガネチユウ4.76	WASHER, PLAIN M 4.76	

IV. 糸切ノ関係 (糸切ノ) / Thread trimmer mechanism (Thread trimmer)

/ Fadenabschneidevorrichtung (Fadenabschneider) / Mécanisme de coupe-fil (Coupe-fil)  
 / Mecanismo de la cortadura de hiros (Cortahílos)

REF.NO.	CODE	Q'TY	ヒンメイ	NAME OF PARTS	RM
40	S07523101	2	イドウハレバー	MOVEBLE KNIFE LEVER	
41	120752001	2	セットカラー	SET SCREW COLLAR	
42	100251001	4	トメネジ6.35	SET SCREW, SM6.35	
43	S07524101	2	イドウハウケ	MOVABLE KNIFE BRACKET	
44	062670812	4	ナベコ3.57-40X8	SCREW, PAN SM3.57-40X8	
45	S07525000	2	シタイトホジバネ	SPRING, PLATE	
46	141544001	4	シメネジ3.18	SCREW, SM3.18	
47	S07526201	2	イドウハ	MOVABLE KNIFE	
48	148536001	4	シメネジ4.37	SCREW, SM4.37	
49	S07527001	2	コテイハ	FIXED KNIFE	
50	148539101	2	ダンネジ2.38	SHOULDER SCREW, SM2.38	
54	S02745001	1	ザガネ	WASHER	
55	062680663	1	ナベコ437-40X6	SCREW, PAN SM4.37-40X6	
59	146354001	1	ザガネ	WASHER, PLAIN 5	
-----					
51	153969000	1	<DCモータ用> ナイロンコネクタ12P	<FOR DC MOTOR> NYLON CONNECTOR (12P)	
52	S03815001	1	コネクタキャップ6	CONNECTOR CAP 6	
53	S18889001	1	アースセンクミ	GROUND WIRE ASSY	
53-1	S03328000	1	ピンターミナルオスL	TERMINAL PIN (L)(MALE)	
53-2	204569001	1	アツタンシ4.5X14	TERMINAL, 4.5X14	
56	S11210000	1	Wコード5クミ	W-CORD (S) ASSY	
56-1	S11684000	1	コネクタ3191-01R1	CONNECTOR, (3191-01R1)	
56-2	143548000	1	ピンターミナルメス	TERMINAL PIN (FEMALE)	
56-3	143549000	1	ピンターミナルオス	TERMINAL PIN (MALE)	
57	S11683000	1	コネクタ3191-01P1	CONNECTOR (3191-01P1)	
58	340400001	2	ユニタイバンド	BEAD BAND	
-----					
53	S06004001	1	<エフカモータ用> -----	<FOR EFKA MOTOR> GROUND WIRE ASSY	
53-2	204569001	2	-----	TERMINAL, 4.5X14	
-----					
47	S29797201	2	" オプションパーツ " <ケブラー糸用> イドウハ	" OPTION PARTS " <FOR KEVLAR THREAD> MOVABLE KNIFE, HARD MATERIAL	
49	S29437001	2	コテイハ コテイハ コテイハ	FIXED KNIFE, HARD MATERIAL	



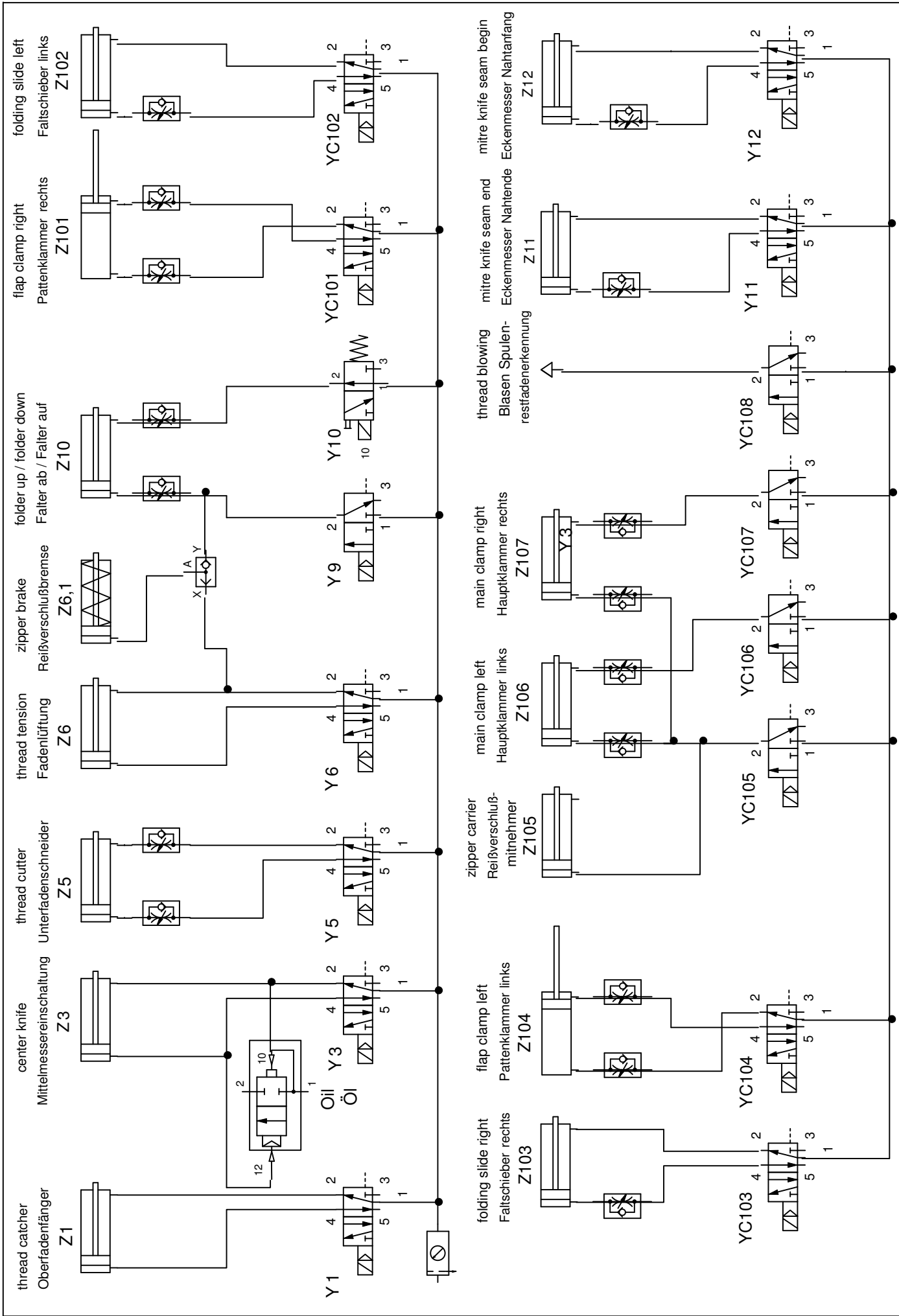

Aenderung		Datum		Name		Benennung:		Zeichnungs-Nr.		Anlage	
a	Z-105-4244	10.9.07	16.01.07	Reichenb	Reichenb	P 100-68		Blatt Nr. 1		Ort	
b	Öl	29.4.08		Reichenb		Pneumatikplan 100 / 68		von 3		Blatt 3	
c	Öl										
d	Öl										

Beisler GmbH  
Frohnradstraße 10  
63768 Hörsbach

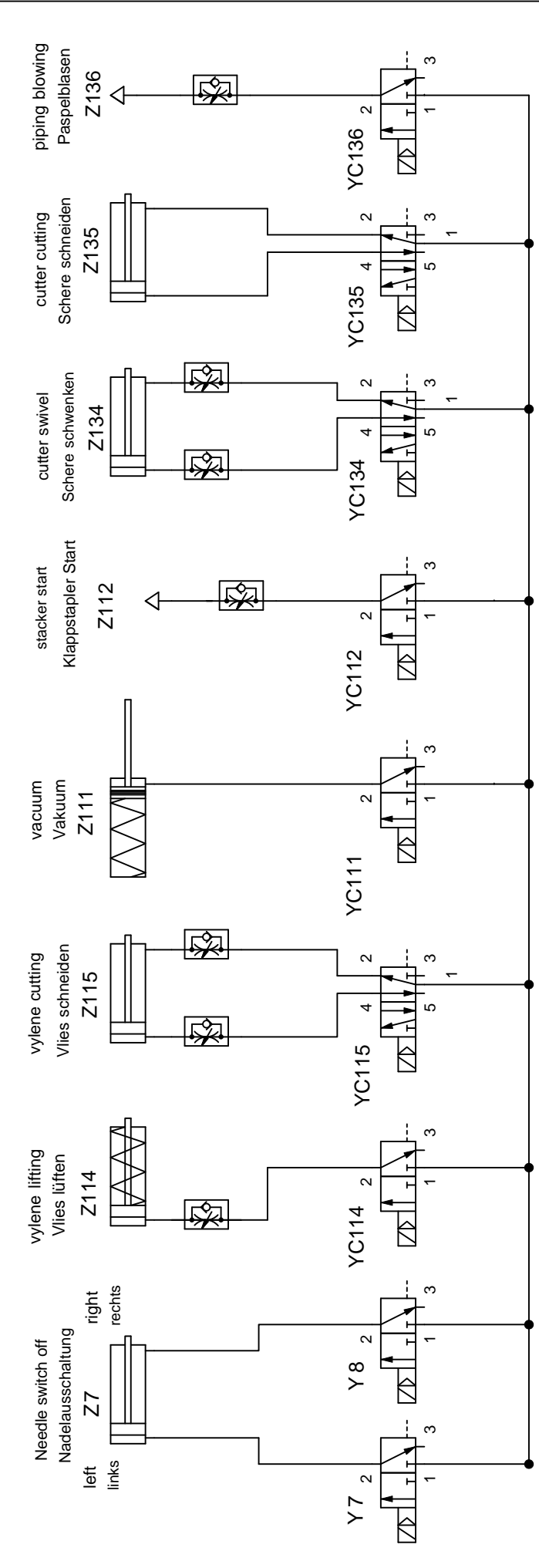
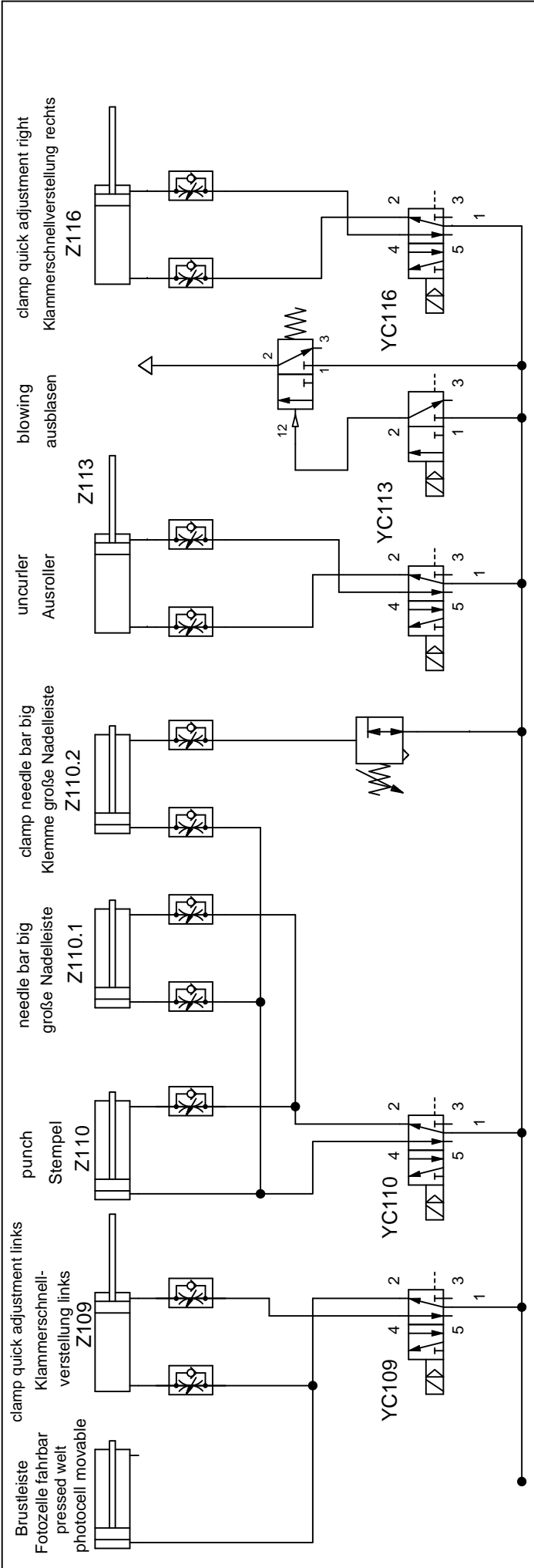

Aenderung		Datum	Name	Benennung:		Zeichnungs-Nr.		Anlage		Blatt	
a				Pneumatikplan 100 / 68		P 100-68		Ort		Nr. 2	
b		gez. 05.02.07	Reichenb							von 3 Blatt	
c											
d											

Beisler GmbH  
Frohnradstraße 10  
63768 Hörsbach

mitre knife left mobile  
Eckenmesser links fahrbar

mitre knife right mobile  
Eckenmesser rechts fahrbar

mitre knife left fixed  
Eckenmesser links fest

mitre knife right fixed  
Eckenmesser rechts fest

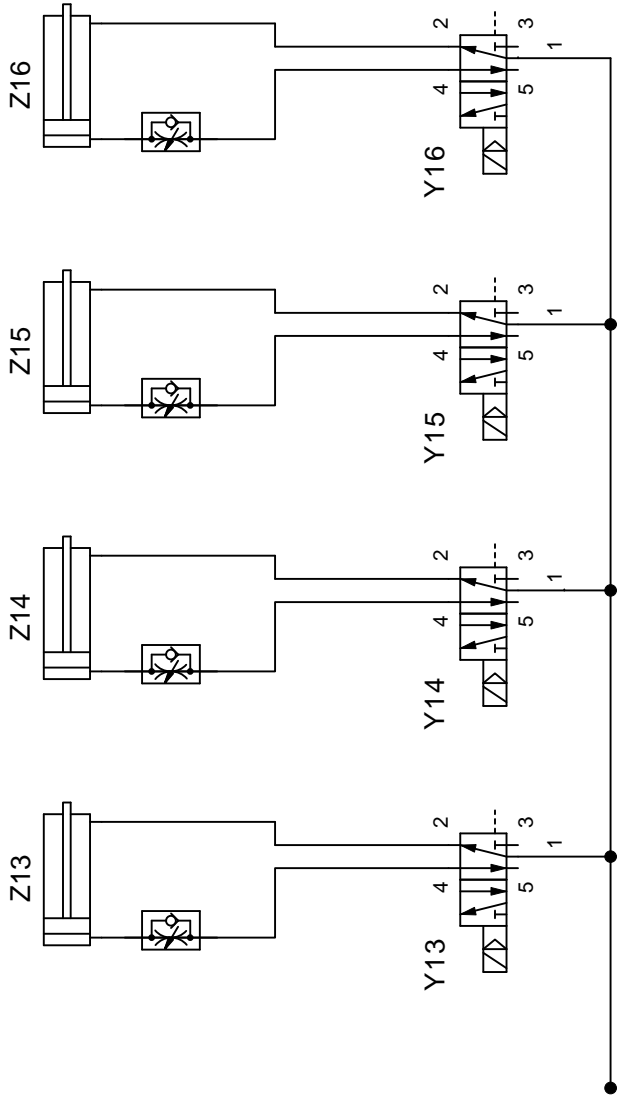

Aenderung	Datum	Name	Datum	Name
a			16.01.07	Reichenb
b				
c				
d				

Benennung:

Pneumatikplan 100 / 68

Zeichnungs-Nr.

P 100-68

Anlage

Ort

Blatt Nr.

von

Blatt 3  
von 3  
Blatt

Beisler GmbH  
Frohnradstraße 10  
63768 Hösbach





advanced sewing equipment

# TEILELISTE

## Klapp-Stapler

201/6

Telefon: (0 60 21) 5 01 9-0

Telefax: (0 60 21) 50 19 -10

# INHALTSVERZEICHNIS 201/6

05. Sep. 97

BENENNUNG	TAFEL PAGE	NAME
KLAPPSTAPLER	1	FOLDING STACKER
KLAPPSTAPLER	2	FOLDING STACKER
UNTERGESTELL 201/6/1	3	BASE FRAME 201/6/1
STAPLERBEFESTIGUNG 201/6/2	4	STACKER FASTENING 201/6/2
STAPLERBEFESTIGUNG 201/6/3	5	STACKER FASTENING 201/6/3
OPTION: ABWEISER	6	OPTION: DEFLECTOR

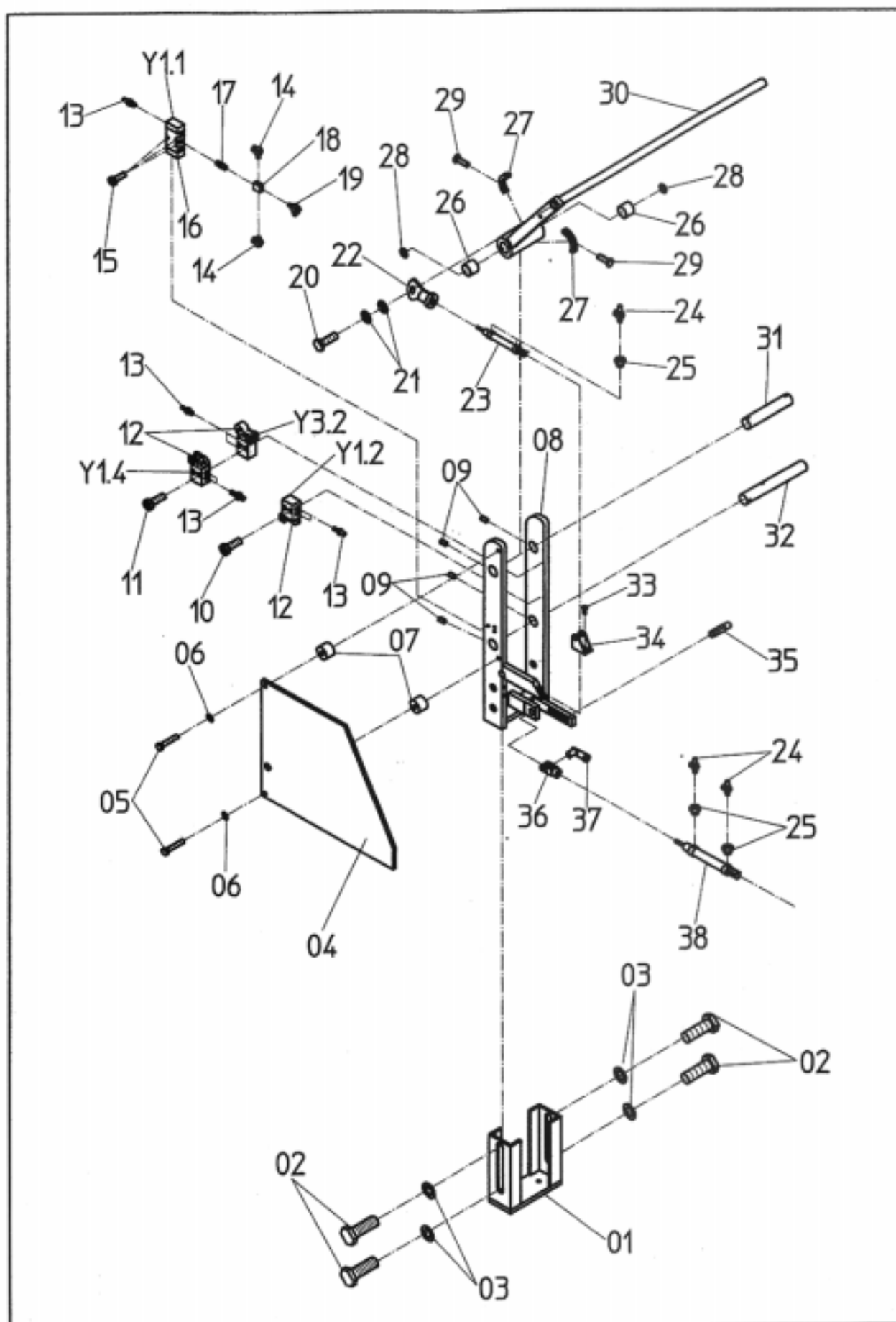

TAFEL 1	KLAPPSTAPLER	201/6
---------	--------------	-------

NR. NO.	ARTIKEL NR: ARTICLE NO:	BEZEICHNUNG	NAME	ST. PIECE
01	7887-00	Grundplatte	base plate	1
02	DIN933 M10*20	Schraube	screw	4
03	DIN9021 Ø10.5	Scheibe	washer	4
04	7447-00	Blech	plate	1
05	DIN 912 M5*45	Schraube	screw	2
06	DIN 125 AØ5.4	Scheibe	washer	2
07	7488-00	Distanzstück	distance piece	2
08	8995-00	Rahmen	frame	1
09	DIN913 M6*15	Schraube	screw	4
10	DIN912 M4*25	Schraube	screw	2
11	DIN912 M4*40	Schraube	screw	2
12	1100249	Ventil	valve	3
13	1400343	Verschraubung	screw joint	9
14	1400341	Verschraubung	screw joint	3
15	DIN912 M3*20	Schraube	screw	2
16	1100195	Ventil	valve	1
17	1300310	Verschraubung	screw joint	1
18	1300324	Verschraubung	screw joint	1
19	1300321	Verschraubung	screw joint	1
20	DIN933 M10*30	Schraube	screw	1
21	DIN125 AØ10.5	Scheibe	washer	2
22	1000202	Gelenkkopf	swivel head	1
23	1000216	Zylinder	cylinder	1
24	6927-00	Drossel	throttle valve	4
25	1300312	Verschraubung	screw joint	4
26	1500423	Buchse	sleeve	2
27	7437-00	Anschlag	impact	2
28	DIN988 162601	Scheibe	washer	2
29	DIN933 M4*8	Schraube	screw	2
30	8989-00	Bügel	stirrup	1
31	7442-00	Welle	shaft	1
32	7443-00	Welle	shaft	1
33	DIN6912 M6*10	Schraube	screw	2
34	1000148	Befestigung	fastening	1
35	7440-00	Bolzen	bolt	1
36	1000217	Gabelkopf	fork crown	1
37	1800531	Bolzen	bolt	1
38	1000215	Zylinder	cylinder	1
201/6		KLAPPSTAPLER		Tafel 1



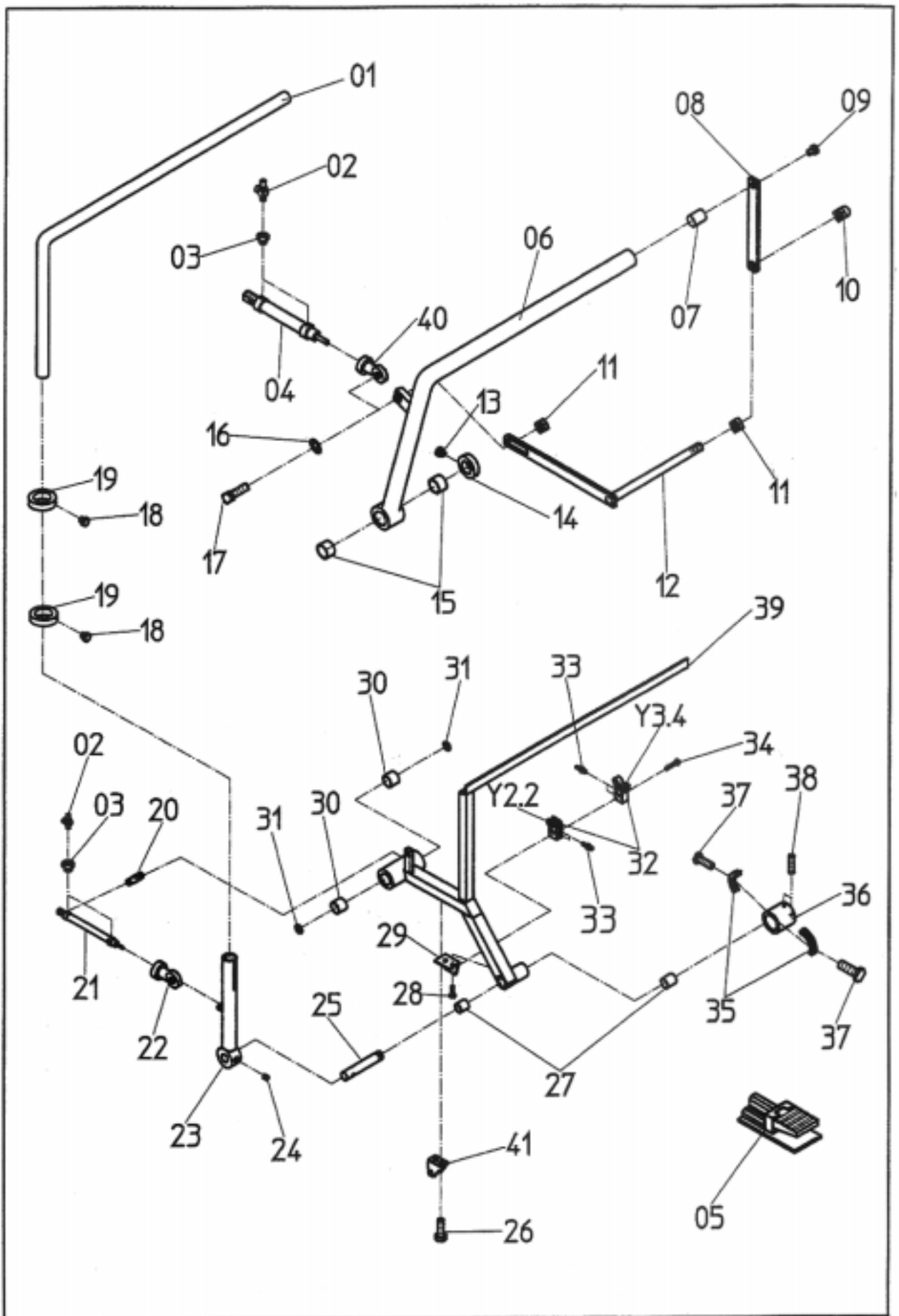

TAFEL 2	KLAPPSTAPLER	201/6
---------	--------------	-------

NR. NO.	ARTIKEL NR: ARTICLE NO:	BEZEICHNUNG	NAME	ST. PIECE
01	8991-00	Rohr	pipe	1
02	6927-00	Drossel	throttle valve	4
03	1300312	Verschraubung	screw joint	4
04	1000215	Zylinder	cylinder	1
05	1100192	Ventil	valve	1
06	7433-00	Bügel	stirrup	1
07	7432-00	Bolzen	bolt	1
08	7431-00	Lasche	cover plate	1
09	DIN912 M6*12	Schraube	screw	1
10	DIN1587 M10	Mutter	nut	1
11	DIN934 M10	Mutter	nut	2
12	7430-00	Bügel	stirrup	1
13	DIN912 M6*6	Schraube	screw	1
14	1600462	Stellring	set collar	1
15	1500439	Buchse	sleeve	2
16	DIN125 A010.5	Scheibe	washer	1
17	DIN933 M10*45	Schraube	screw	1
18	DIN912 M6*08	Schraube	screw	2
19	8145-00	Stellring	set collar	2
20	7441-00	Welle	shaft	1
21	1000214	Zylinder	cylinder	1
22	1500394	Gelenkkopf	swivel head	1
23	8993-00	Bügel	stirrup	1
24	DIN913 M8*10	Schraube	screw	1
25	7429-01	Welle	shaft	1
26	DIN6912 M6*10	Schraube	screw	2
27	1500433	Buchse	sleeve	2
28	DIN912M4*10	Schraube	screw	2
29	11375-00	Winkel	square	1
30	1500423	Buchse	sleeve	2
31	DIN988 162601	Scheibe	washer	2
32	1100249	Ventil	valve	2
33	1400343	Verschraubung	screw joint	4
34	DIN912 M4*35	Schraube	screw	1
35	7437-00	Anschlag	impact	2
36	7436-00	Welle	shaft	1
37	DIN933 M4*8	Schraube	screw	2
38	DIN913 M6*8	Schraube	screw	2
39	8994-00	Bügel	stirrup	1
40	1000202	Gelenkkopf	swivel head	1
41	1000148	Befestigung	fastening	1

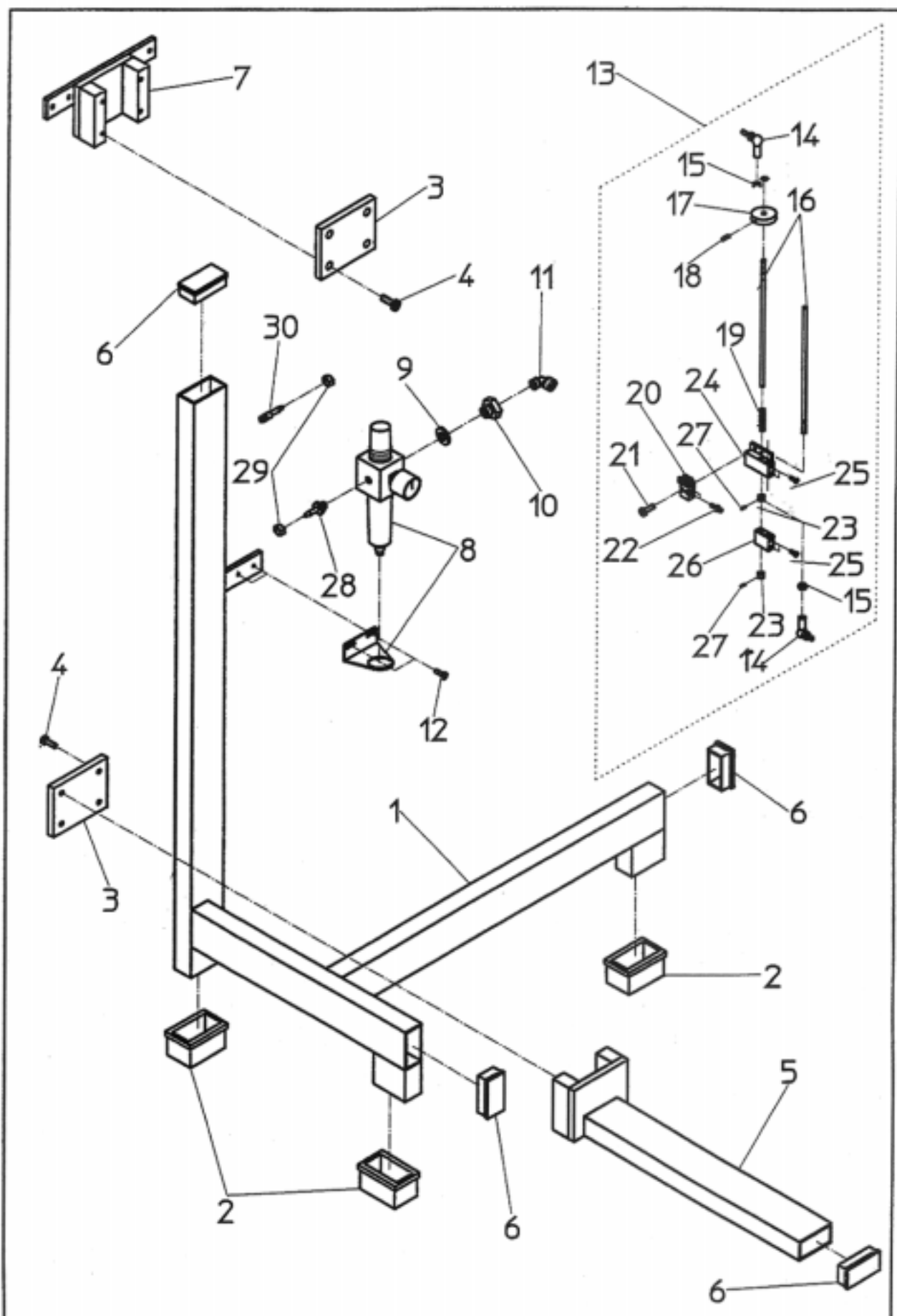

Tafel 3

UNTERGESTELL

201/6/1 & 201/7/1

NR. NO.	ARTIKEL NR: ARTICLE NO:	BEZEICHNUNG	NAME	ST. PIECE
01	130-00	Untergestell	base frame	1
02	2500872	Gummifuß	rubber foot	3
03	51-00	Platte	plate	2
04	DIN912 M6*15	Schraube	screw	8
05	131-00	Stütze	support	1
06	2600873	Verschlußstopfen	stopper	4
07	132-00	Tischklemme	table clamp	1
08	1200272.99	Fillerregler	filler controller	1
09	1100242	Dichtung	gasket	1
10	1300261	Verschraubung	screw joint	1
11	1300287	Verschraubung	screw joint	1
12	DIN912 M4*8	Schraube	screw	2
13	2500900	Fußtritteinheit	treadle unity	1
14	1500389	Winkelgelenk	pivot screw	2
15	DIN934 M6	Mutter	nut	2
16	143-00	Gestänge	linkage	2
17	139-00	Schaltnocken	trip dog	1
18	DIN913 M4*10	Schraube	screw	1
19	1700490	Feder	spring	1
20	1100249	Ventil	valve	1
21	DIN912 M3*20	Schraube	screw	2
22	1300306	Verschraubung	screw joint	2
23	1600465	Stellring	set collar	2
24	140-00	Ventilhalter	valve holder	1
25	DIN933 M4*6	Schraube	screw	4
26	138-00	Klemmhülse	clamp collar	1
27	DIN913 M4*4	Schraube	screw	2
28	1400372	Schlauchnippel	tube connector	1
29	1400373	Schlauchklemme	tube clamp	1
30	1400363	Stecknippel	male coupling	1

201/6/1 & 201/7/1

UNTERGESTELL

Tafel 3

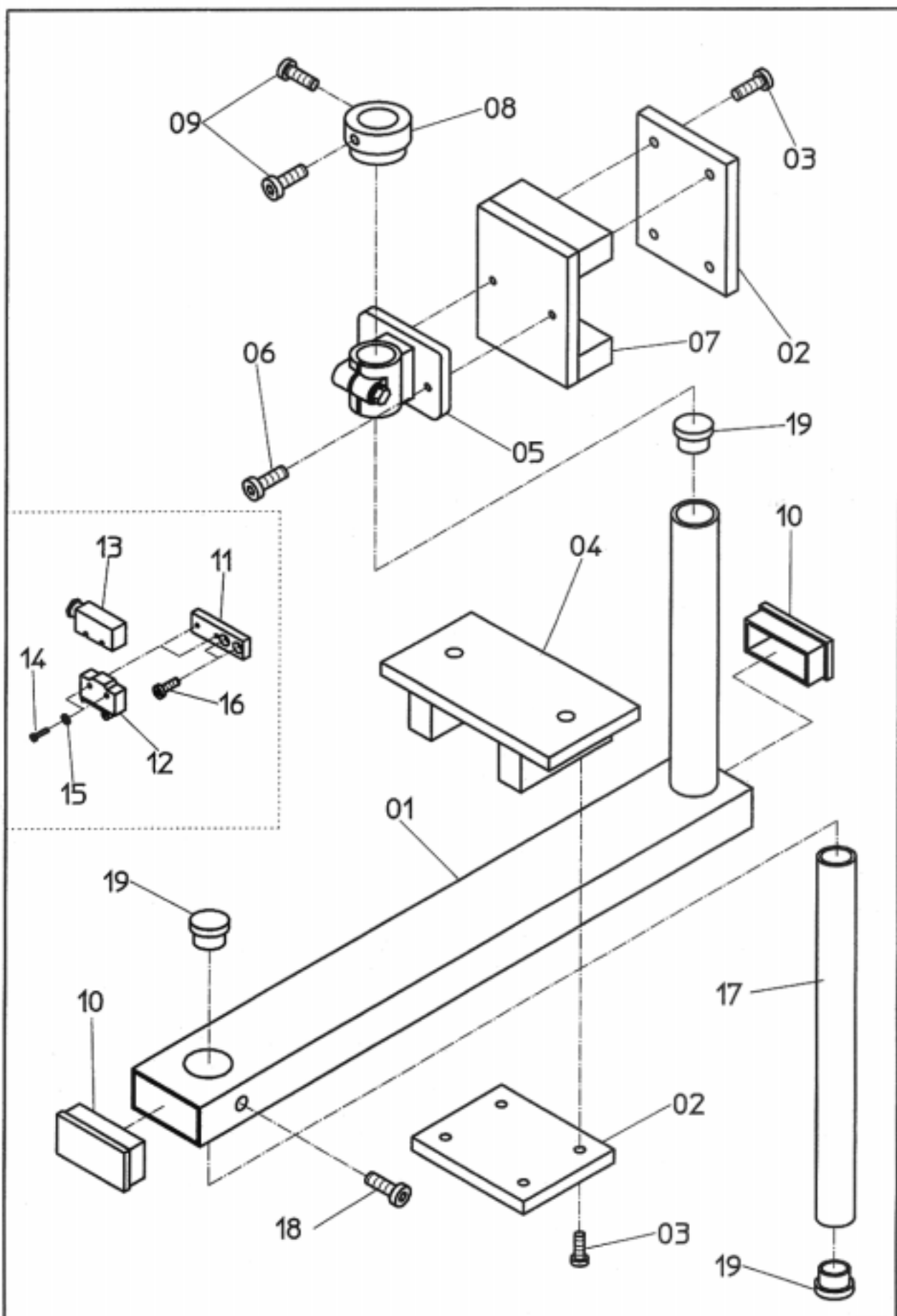

Tafel 4

STAPLERBEFESTIGUNG

201/6/2 & 201/7/2

NR. NO.	ARTIKEL NR: ARTICLE NO:	BEZEICHNUNG	NAME	ST. PIECE
01	2313-00	Befestigung	fastening	1
02	51-00	Platte	plate	2
03	DIN912 M6*20	Schraube	screw	8
04	8986-00	Klemme	clamp	1
05	1600439	Klemme	clamp	1
06	DIN912 M6*15	Schraube	screw	2
07	6661-00	Klemme	clamp	1
08	5770-00	Stellring	set collar	1
09	DIN912 M6*10	Schraube	screw	2
10	2500873	Verschlussstopfen	stopper	2
11	8987-00	Halter	holder	1
12	2000550	Mikroschalter	micro switch	1
13	2000563	Abdeckkappe	cover	1
14	DIN912 M3*18	Schraube	screw	2
15	DIN125 A03.2	Scheibe	washer	2
16	DIN912 M4*5	Schraube	screw	2
17	7889-00	Rohr	pipe	1
18	DIN912 M6*18	Schraube	screw	1
19	2500877-02	Verschlussstopfen	stopper	3

201/6/2 & 201/7/2	STAPLERBEFESTIGUNG	Tafel 4
-------------------	--------------------	---------

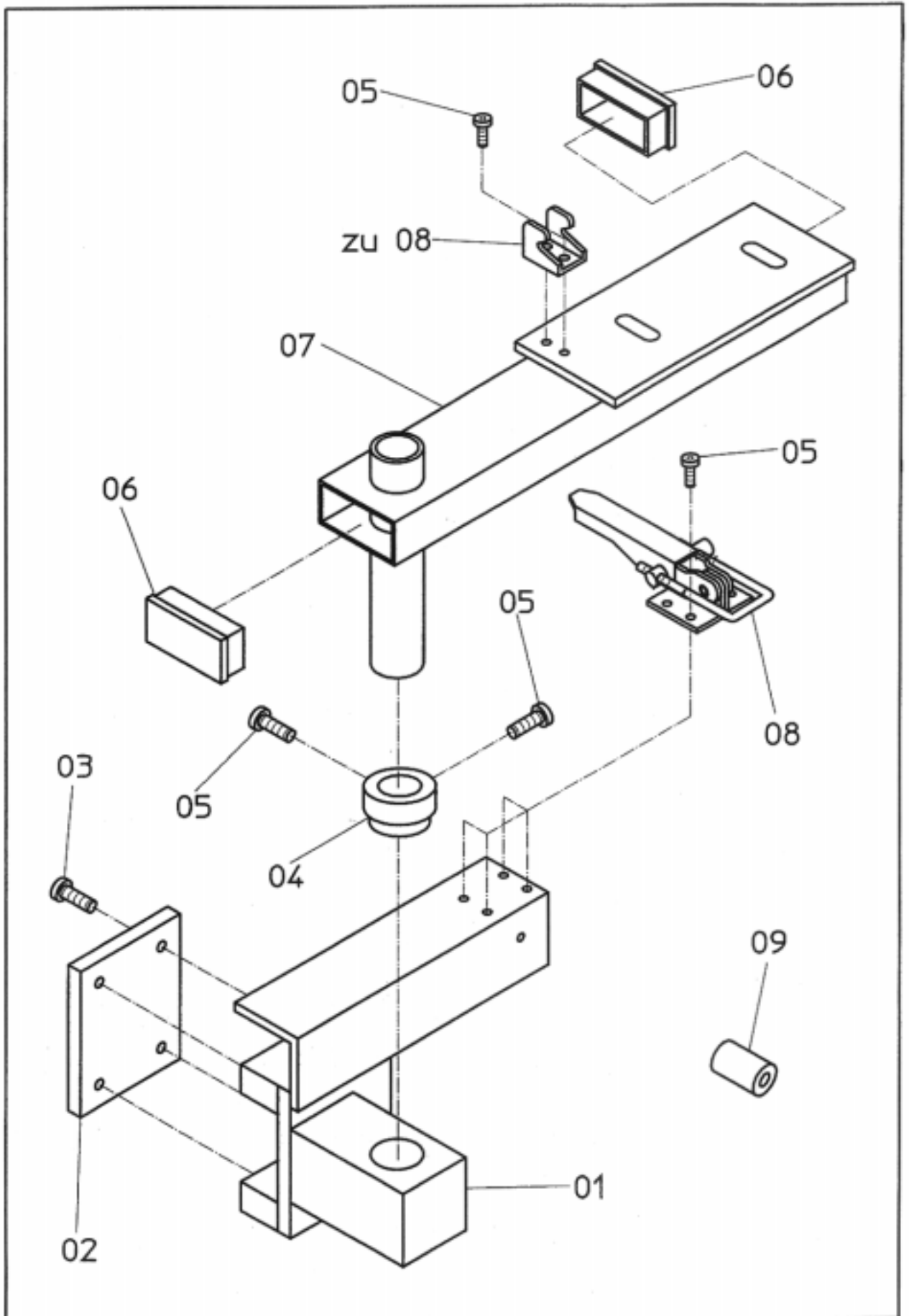

Tafel 5	STAPLERBEFESTIGUNG	201/6/3 & 201/7/3
---------	--------------------	-------------------

NR. NO.	ARTIKEL NR: ARTICLE NO:	BEZEICHNUNG	NAME	ST. PIECE
01	8659-00	Staplerklemme	stapler clamp	1
02	51-00	Platte	plate	1
03	DIN912 M6x20	Schraube	screw	4
04	5770-00	Stellring	set collar	1
05	DIN912 M6x10	Schraube	screw	8
06	2500873	Verschlußstopfen	stopper	2
07	8658-00	Befestigung	fastening	1
08	1600514	Schnellverschluß	quick fastener	1
09	9116-00	Distanzrolle	spacer	1
201/6/3 & 201/7/3		STAPLERBEFESTIGUNG		Tafel 5



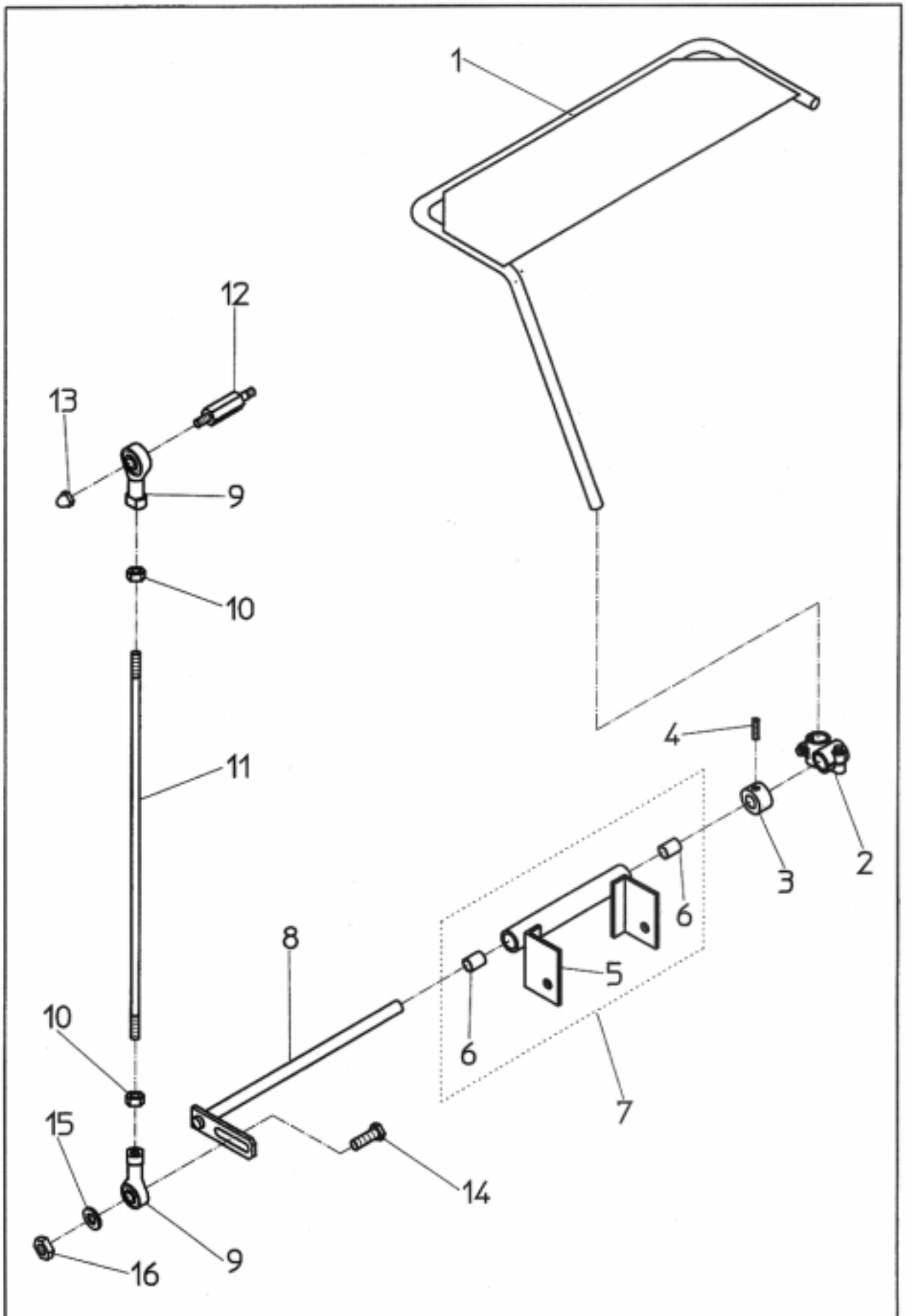

Tafel 6	OPTION: ABWEISER	201/6 & 201/7
---------	------------------	---------------

NR. NO.	ARTIKEL NR: ARTICLE NO:	BEZEICHNUNG	NAME	ST. PIECE
01	9049-00	Abweiser	deflector	1
02	1600436	Klemme	clamp	1
03	1600462	Stellring	set collar	1
04	DIN913 M6*8	Schraube	screw	1
05	9048-00	Halter	holder	1
06	1500439	Buchse	sleeve	2
07	91.9048-00	Halter komplett	holder complete	1
08	9046-00	Halter	holder	1
09	1000202	Gelenkkopf	swivel head	2
10	DIN934 M10*1,25	Mutter	nut	2
11	9047-00	Gewindestange	hread bar	1
12	9045-00	Stehbolzen	slay bolt	1
13	DIN1587 M10	Hutmutter	cup nut	1
14	DIN933 M10*30	Schraube	screw	1
15	DIN125 AØ10,5	Scheibe	washer	1
16	DIN934 M10	Mutter	nut	1

201/6/2 & 201/7/2

OPTION: ABWEISER

Tafel 6

SCHWENKBÜGEL

KLEMMBÜGEL

ÜBERWURFBÜGEL

ABLAGEBÜGEL

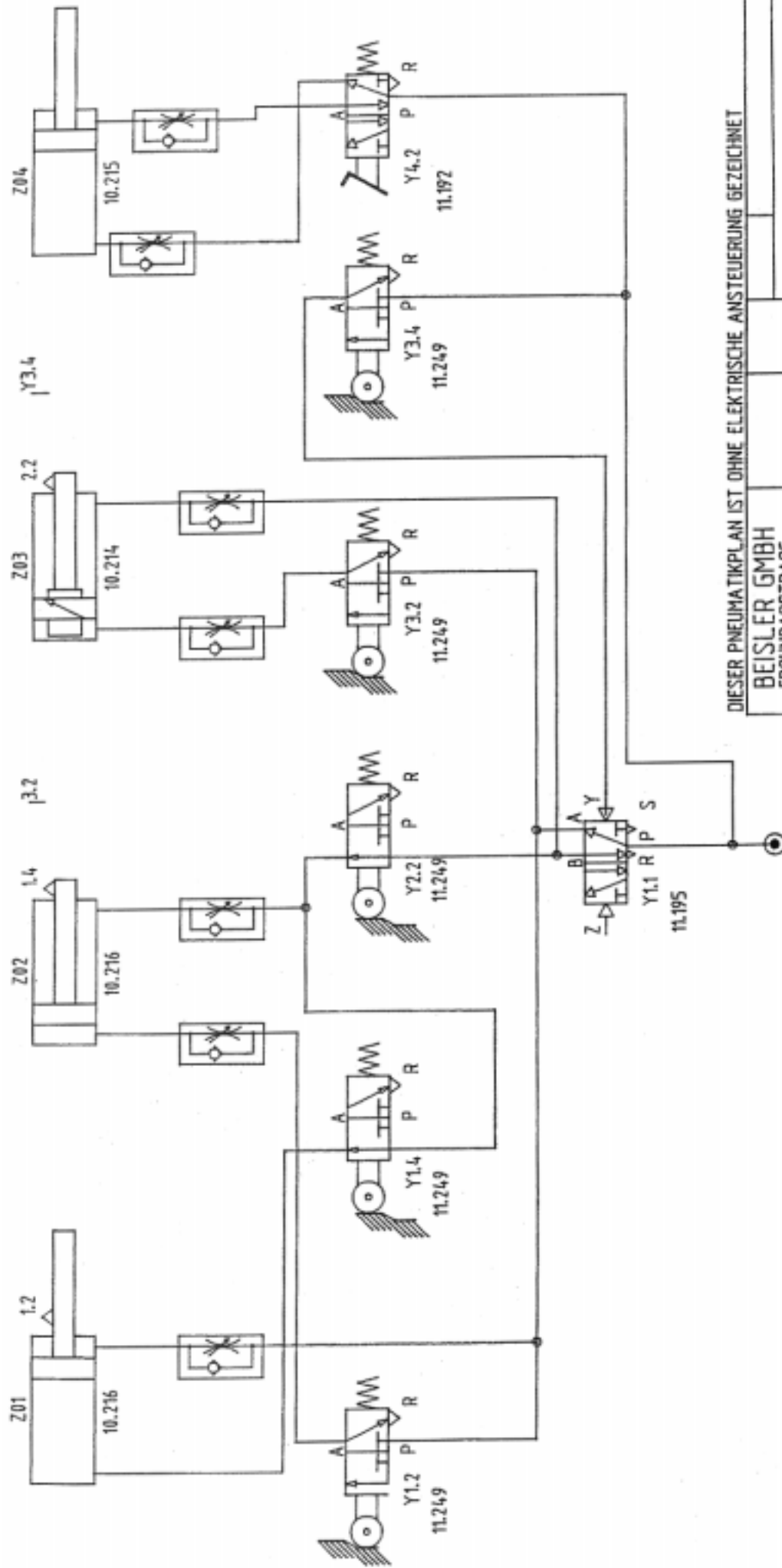

DIESER PNEUMATIKPLAN IST OHNE ELEKTRISCHE ANSTEUERUNG GEZEICHNET

BEISLER GMBH  
FRÖHNRAUSTRASSE  
8759 HÜSBACH

1991 DATUM NAME

ZEICHNUNG N. N. VERFÄHRER

SEITE

DES

PROJEKTS

NR.

201/5

PNEUMATIKSCHALTPLA

44.00201050001



**DÜRKOPP ADLER AG**

Potsdamer Straße 190

33719 Bielefeld

GERMANY

Phone +49 (0) 521 / 925-00

E-Mail [service@duerkopp-adler.com](mailto:service@duerkopp-adler.com)

[www.duerkopp-adler.com](http://www.duerkopp-adler.com)