

# Instructions and Maintenance



## SERIES MINI 4



**ROTONDI**<sup>®</sup> group

*A step ahead*



## INSTRUCTIONS AND MAINTENANCE MOD. MINI 4

**Read these directions carefully before operating.**  
**Don't use the machine differently from the following description.**

### 1. SPECIFICATIONS

MODEL:	<b>MINI 4</b>
POWER SUPPLY:	230 V / Hz 50-60
TOTAL INSTALLED POWER:	W 2250
IRON POWER:	W 800
BOILER POWER:	W 1450
BOILER CAPACITY:	L. 3,4
IRONING ENDURANCE:	about 3 hours
OPERATING STEAM	2,8 BAR
MAXIMUM PRESSURE:	5 BAR
WEIGHT:	KG. 11,5
OVERALL DIMENSIONS:	cm 25x29x37 h.
<b>MADE IN ITALY</b>	

### 2. IMPORTANT

Before installing MINI 4, it is necessary to set up the following facilities:

1. electrical plug protected and suitable to MINI 4 power (it is better to use an earth protector magnetothermic switch 16 A Id 30mA).
2. a steady and plane surface where to put the machine.

For the transport and the displacement, take the generator only by the handle, never pull its electric wires (fig. 1).

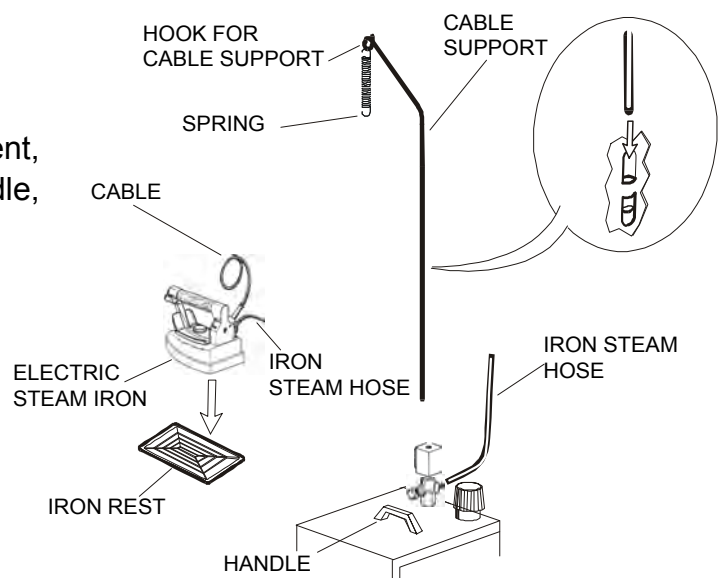

**Fig. 1**

### 3. OPENING OF PACKAGE

1. Open the box containing MINI 4, take the instructions manual and read it carefully.
2. Remove MINI 4 from the box, insert the cable support deep into the special support holder (fig. 1) placed on the back side of the generator.
3. Fix iron cable to the support hook (avoid twining).
4. Put the iron on its rubber iron rest (Fig.1).
5. For MINI 4 supplied with trolley: screw the trolley knob on the proper connection under the base of the machine .

### 4. CONNECTION AND STARTING

With MINI 4 switched off and disconnected plug:

1. Unscrew the security valve plug (fig. 1), fill the boiler with water (fig. 2-4) till overflow or at pleasure. Take the plug by the plastic part and screw it again: do not tighten too much or its gasket might get spoilt.
2. Insert the plug into a 220 V 16 A socket.
3. Switch on the boiler (fig. 2 B), the iron (fig. 2 C) and adjust the thermostat (fig. 5) on "cotton".
4. Wait for the boiler lamp to switch off (fig. 2 A).  
At this point seize the iron by cork handle and press red button 3 or 4 times (fig. 6), so that steam comes out: this operation must be carried out in order to heat up the tubes which take steam to the iron. In this way you prevent also the falling of small drops of water on garments. To adjust steam flow, you must work on the hand-wheel for steam adjustment (fig. 3). During ironing operation, the boiler lamp switches on and off (fig. 2 A).

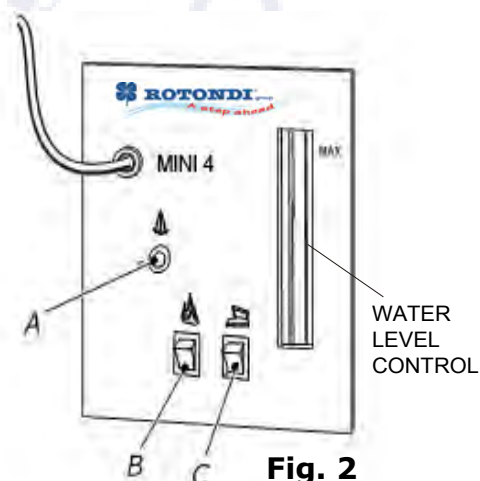

**Fig. 2**

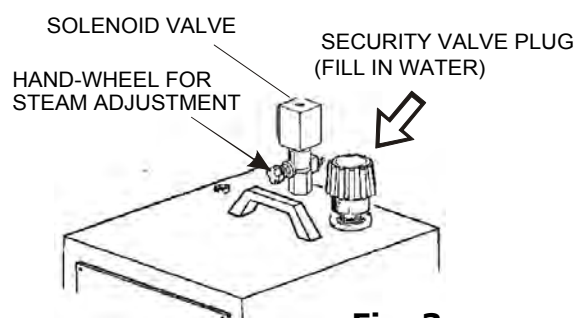
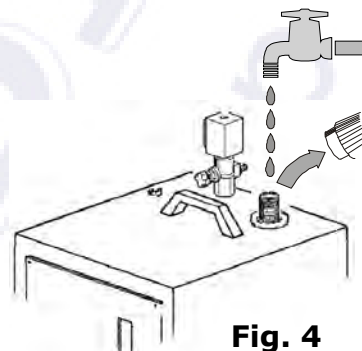

**Fig. 3**

### 5. COMPULSORY

1. Use only normal water coming from the aqueduct.
2. Never add additives to water.
3. Empty the boiler only when it is switched off and cold (with no pressure). For carrying out this operation, wear gloves against possible burns.

4. **Never replace the security valve plug (fig.3) with other types of plug. P.S. the security valve plug is set on 4,5 BAR and it has the function of a security valve.**
5. Connect MINI 4 to suitable protected socket.
6. Always keep children away from MINI 4, both when it is on and off.
7. Do not iron garments directly on persons or things.
8. Do not empty the boiler during the ironing operation, wait at least 1 hour after the switching off.
9. Do not leave hot iron on garments or on the board.
10. Do not leave hot iron on garments or on the board. Put the trolley on a steady surface and next to the ironing board. Do not pull the iron cable too hard or the trolley might be overturned.



**Fig. 4**

## 6. IRONING OPERATION

1. Run the iron on garments, pressing the iron microswitch (fig. 6) for steam. For a better result, set the thermostat (fig. 5) on "cotton".
2. For delicate, blue and black garments, we advise you to use the anti-shine shoe.
3. During ironing operation, always put the iron on its rubber rest (fig. 1) and pay attention to the position of the wires: if they twine or get in touch with ironing board, they might cause short circuits.
4. For dry ironing it is possible to adjust the thermostat (fig. 5) on different positions according to the type of fabric (look at garment label). For steam ironing set the thermostat on "cotton" or "linen".
5. If you work on a non-vacuum board, some circular water spots might form because of condensed steam. To get round this problem, put a felt under the usual padding and adjust the hand-wheel for steam regulation on minimum (fig. 3).

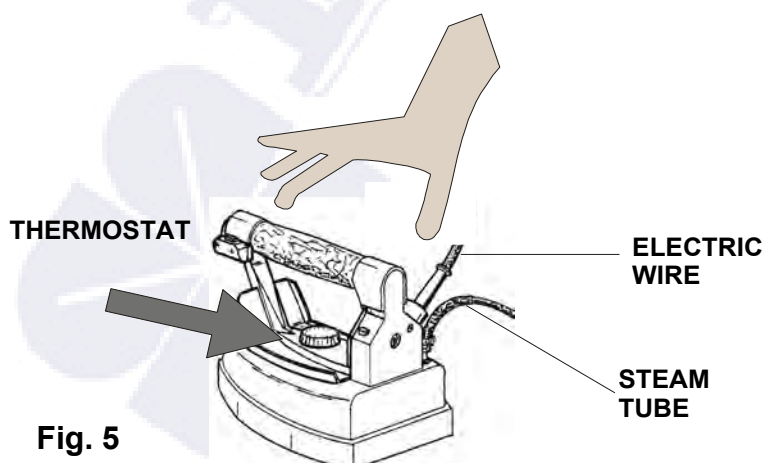

**Fig. 5**

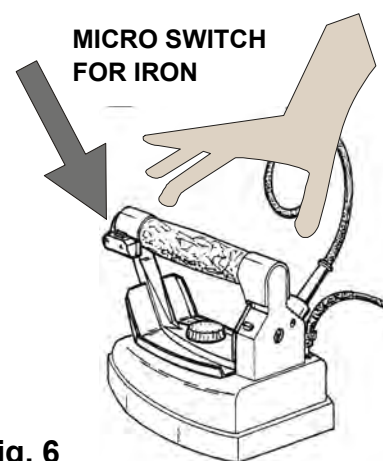

**Fig. 6**

## **7. WATER FILLING**

During the ironing, if steam flow decreases considerably and then ends definitely, it means that there is no more water in the boiler. So MINI 4 has to be switched off by disconnecting the plug; rotate the valve plug (fig. 3) of 360° and wait for steam to go out completely. Unscrew the valve plug with care and wait some minutes. Then fill the boiler with water (fig. 4). Screw the valve plug again, connect the plug and wait for the boiler lamp to switch off (fig. 2 A). Now the iron is ready again.

**ATTENTION:** MINI 4 must always be on horizontal position.

## **8. BOILER DISCHARGE**

Carry out this operation when the machine is off and the plug disconnected: unscrew the valve plug and rotate MINI 4 rightwards so that water and possible impurities come out.

## **9. GOOD FUNCTIONING**

MINI 4 was designed for the ironing of domestic garments and tailor shop. It can be used maximum 20 hrs. per week or 80 hrs. per month (subdivided in many times).

## **10. INTERVENTIONS AND SMALL REPAIRS**

1. Empty the boiler every 20 hrs. of ironing.
2. Replace the gasket of security valve plug (use only original gaskets) every 1200 hrs. of lighting or maximum 2 years. For carrying out this operation, the machine has to be switched off and cold.
3. Replace the security valve plug every 2500 hrs. of working or maximum 3 years (fig. 1). For carrying out this operation, the machine has to be switched off and cold.

## **11. COMPULSORY PERIODICAL MAINTENANCE**

**(To be carried out exclusively by Assistance Centres or by the Manufacturer)**

It is needed to replace:

1. the internal security valve every 1400 hrs. of ironing or maximum 3 years;
2. the internal thermostat every 1400 hrs. of ironing or maximum 3 years;
3. steam tube and iron cable once they seem spoilt (fig. 3).

It is recommended also to clean the boiler from limestone every 1400 hrs. of ironing or maximum 3 years.

## 12. ELECTRICAL RISKS

The following situations are considered dangerous for the operator:

1. earth protector switch is activated when turning on the main switch,
2. using MINI 4 during thunderstorms,
3. when using MINI 4 without shoes or with improper shoes or with wet feet
4. damage of iron cables,
5. leaking of water from iron,
6. iron overheating
7. if washing or cleaning the iron with iron
8. when filling MINI 4 with water is switch on
9. if MINI 4 is leaking water

## 13. MECHANICAL RISKS

The following situations are considered dangerous for the operator:

1. using MINI 4 for different purposes other than ironing,
2. replacing the valve plug gasket with non-original gaskets.

## 14. THERMIC RISKS

The following situations are considered dangerous for the operator:

1. touching iron base when working,
2. touching the solenoid valve when the machine is under pressure
3. touching the valve plug when the machine is under pressure,
4. opening the valve plug when the machine is under pressure,
5. directing steam towards persons or animals.

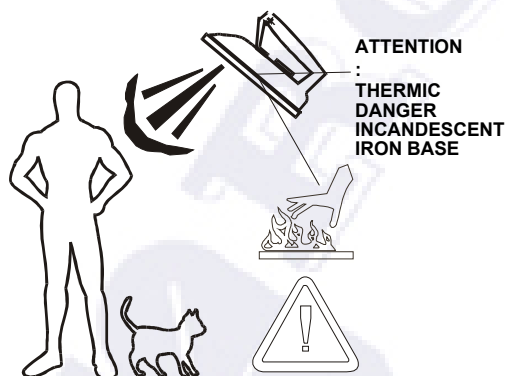

- Do not iron garments directly on persons.**
- Do not leave hot iron on garments.**
- After use, always put iron on its iron rest.**

## 15. PACKING, STORAGE AND TRANSPORT

MINI 4 can be packed with cellophane, on pallet or in cardboard box (never turn it upside down!). It is not a stiff package, therefore it is not shock-resistant. We advise you to handle the box with maximum care. Do not use it as stool or support. MINI 4 cannot be piled one on top of another (HANDLE WITH CARE).

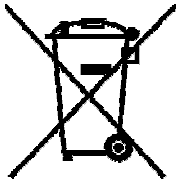
**16. WASTE**

**Information for the correct disposal in accordance with EC directives 2002/96/EC and 2003/108/EC.**

MINI 3 is mainly made of iron material and must therefore not be disposed of as urban waste but in proper waste collection centres. The crossed dustbin symbol indicates that the product must be disposed of separately from other refuse in order to avoid negative consequences for the environment and health.

**PLS. follow your local laws about disposal.**

**17. GUARANTEE CONDITIONS**

The manufacturer guarantee is no more valid when:

- the machine is tampered or repaired by non-authorized personnel,
- there is total or partial inobservance of this manual,
- the machine is badly maintained or wrongly assembled,
- the spare parts replaced are not original.

~~~~~  
**Every product manufactured by ROTONDI GROUP S.r.l. is subject to the following limitations:**

**ROTONDI GROUP S.r.l.** guarantees that this machine, correctly installed and used, works accordingly to this manual of instructions. Each implicit guarantee is limited by law as from purchase date.

**Declination of responsibility for consequential damages: ROTONDI GROUP S.r.l.** will never take the responsibility for any damage (included, without any limitation, consequential damages due to loss or no profit, cutback or any other economical loss) deriving from the use of a ROTONDI GROUP machine, even in case the Company had been previously informed of such kind of possibility.

Should you need further information about this manual, please contact **ROTONDI GROUP S.r.l.** or the person who sold you the machine.

~~~~~



**18. REFERENCE TO NORMS AND TERMINOLOGY EMPLOYED**

Indications contained in the following documents were used in the compilation of the present manual:

- UNI EN ISO 12100 - Machinery safety: general principles for design - risk assessment and risk reduction
- EN 294 - Machinery safety: Stop equipment to prevent the attainment of dangerous areas whit upper limb
- EN 418 - Machinery safety: Equipment of Emergency stop - Functional aspects of design principles
- EN 60204.1 - Machinery safety: Electrical equipment of machinery
- EN 349 - Machinery safety: Minimum distance to avoid crushing of body parts
- DIRECTIVE P.E.D. 97 / 23 / CEE
- DIRECTIVE 2006/95/EC on the harmonisation of the laws
- DIRECTIVE 2004/108/EC Electromagnetic compatibility
- DIRECTIVE 2006/42/EC Machinery directive

See drawing representing steam iron's spare parts

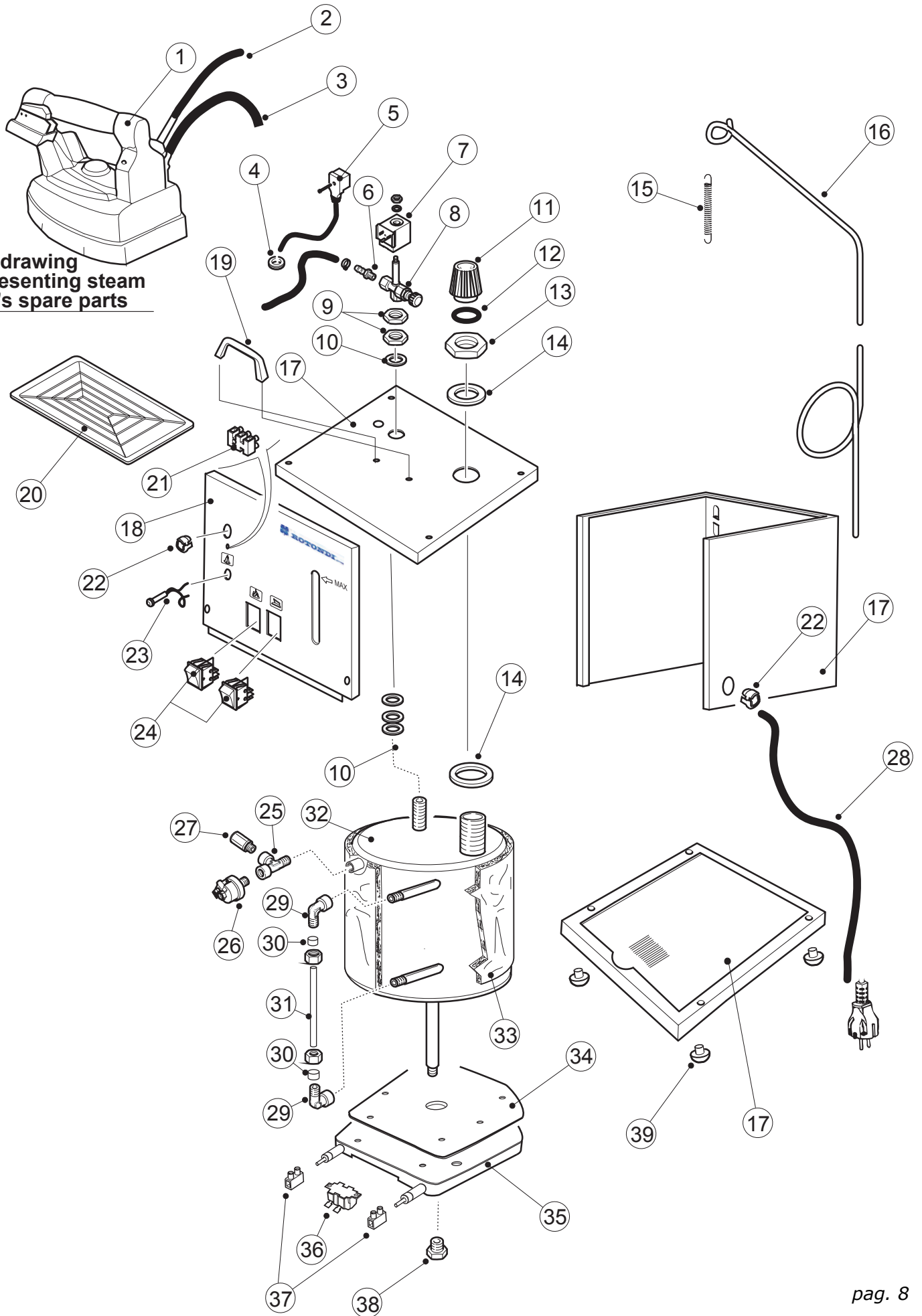

**Spare parts**

<b>POS.</b>	<b>Q.ty</b>	<b>DESCRIPTION</b>	<b>PART NUMBER</b>
1	1	Iron	REC100
2	1	Iron cable 4x1	3060004
3	1	Iron steam hose	3067012
4	1	Rubber cable holder	3067029
5	1	Connector	3067004
6	1	Fitting steam 1/4"	3067030
7	1	Coil	3067005
8	1	Solenoid valve 1/4"	3067006
9	2	Nut 1/4"	3067031
10	2	Washer 1/4"	3067032
11	1	Safety cap 1/2"	3067057
12	1	Ring for cap 1/2"	3060006
13	1	Nut 1/2"	3067033
14	2	Washer 1/2"	3067034
15	1	Spring cable holder	3067035
16	1	Cable support	3067001
17	1	Shell	3067036
18	1	Front panel	3067036
19	1	Handle	3067037
20	1	Iron rest	3067010
21	1	Terminal block	3067002
22	2	Cable holder	3067014
23	1	Pilot light	3067017
24	2	Switch 16 A	3067018
25	1	T - Fitting 1/8"	3067027
26	1	1/8" Pressostat 2,8 Bar	3067028
27	1	1/8 Safety valve 5 Bar	3067021
28	1	Electric cable	3067039
29	2	Fitting for water level control	3067040
30	2	Ring for water level control	3067041
31	1	Water level control glass	3067042

**Spare parts**

POS.	Q.Ty	DESCRIPTION	PART NUMBER
32	1	Boiler	3067043
33	1	Boiler insulation	3067044
34	1	Element ring	3067022
35	1	Element 1450 W	3067045
36	1	165°C Thermostat + thermofuse 298°C	3067046
37	2	Terminal block	3067025
38	1	Cap 1/4"	3067047
39	4	Rubber feet	3067048

**Iron Mod. EC100**

POS./CODE	DESCRIPTION
3033024	Spacer
3014002	Micro switch
3026208	Fitting 1/4"
3033032	Cable holder
3033041	Iron plate
3033042	Red micro cover
3060004	Cable 4 x 1
3060087	Cork handle
13033040	Thermostat + thermofuse
13033068	Knob
R202	Metal filter
R203	Filter stopper
R206-207-208	Electric wires
R215	Cover
3060058	Handle support
3060093	Back handle cover
13033041	Front micro support
R243	Micro wire

**Iron Mod. EC100**

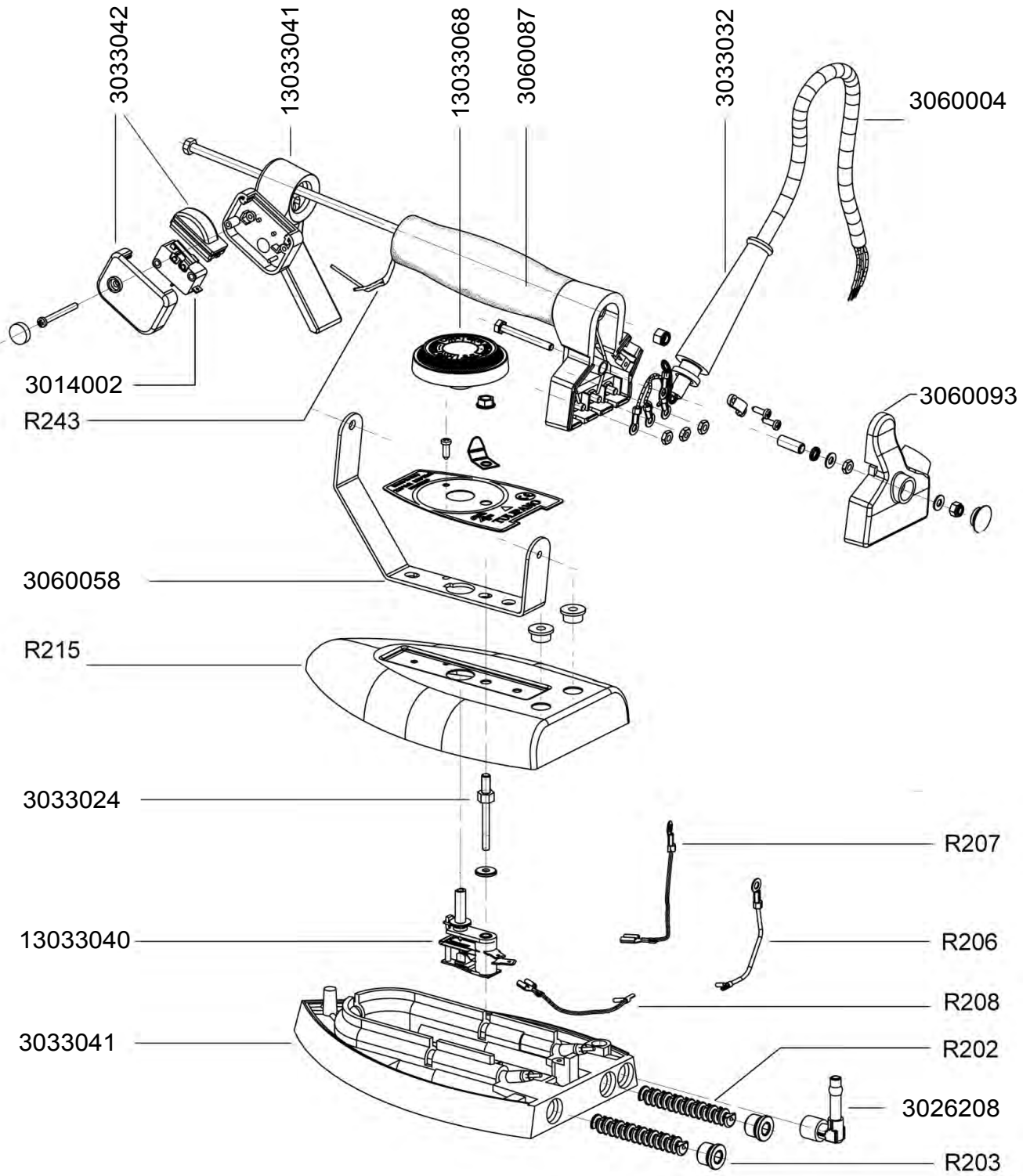

## Accessories

### DESCRIPTION

Vacuum table Mod. Mini 9



Arm RA1 for vacuum table



**Accessory**

Series Mini 3 Inox



Series Mini 4



Series Mini 5



Series Mini 5 with trolley



CE